

INSULATED CONDUCTOR SYSTEMS

U 20 – U 30 – U 40



INSULATED CONDUCTORS U 20 – U 30 – U 40

INDEX	U 20	U 30	U 40
	Page	Page	Page
Basic description	4	4	4
Selection of conductors	5-10	5-10	5-10
Conductors	11	24	34, 35
Rigid joints	11	25	36
Expansion joints	12	25	36
Locating clamps	14	26	36
End caps	14	26	36
Feed terminals	12	26	37
Contact paste	12	26	36
Transfer guides	13	27	38
Transfer funnels	13	29	–
Sectionalizing	13	27	38
Hangers	14	28	39
Insulators	14	28	39
Rail holders	14	28	39
Compact hangers/Attachment hardware/Bracket profiles	15	29	–
Collectors	16, 17	30	40
Components and spares for collectors	18-22	30-33	41
Examples for ordering	23	31	42
Grounding device	43	43	43
Questionnaire	44, 45	44, 45	44, 45
Typical installations	46	46	46

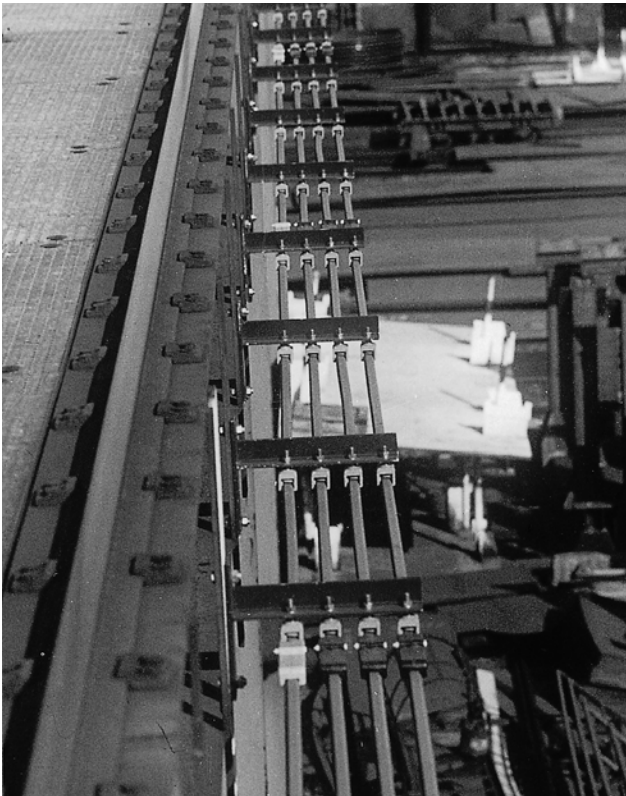

VAHLE U 30 crane runway electrification



VAHLE U 20 amusement ride electrification



GENERAL SELECTION OF CONDUCTORS ENGINEERING DATA pages 4 – 10

U 20

For cranes, self-propelled monorail carriers, amusement rides – for installations with curves, switches, turntables, special control conductor systems for pickling lines and galvanizing plants

pages 11 – 23

U 30

For bridge and portal crane electrification, heavy monorail systems, amusement rides, construction and maintenance hoists and for high voltage applications up to 10 kV

pages 24 – 33

U 40

For heavy cranes and loading bridges, container and transtainer systems, coking machinery, for dockside trench type electrification systems in ports, shipyards and steel mills – for all heavy duty and for high voltage applications up to 10 kV

pages 34 – 42

GROUNDING DEVICE

page 43

QUESTIONNAIRE

pages 44, 45

TYPICAL INSTALLATIONS

page 46



INSULATED CONDUCTORS

General

VAHLE insulated conductors are designed in accordance with international safety regulations for a multitude of power supply applications. They fully meet VDE 0100 and are finger safe to EN 60529 (VDE 0470, part 1, protection code IP 23). They are UL, SAA and SEV approved.

For current collectors touch protection is only given if carbon brushes are fully entered into the conductors. Conductor installations in the reach of hand, where collectors leave the conductor rails during normal operation, must be protected against accidental touch by the customer e.g. switch-off or separation. This refers to voltages above 25 VAC resp. 60 VDC, only.

The adjacent picture demonstrates that the VDE test finger cannot reach live conductors – finger safety is guaranteed.

For high voltage applications we do recommend our adequate high voltage insulators but applicable international or local safety requirements have to be considered.

The shrouding which envelops the various conductors is an excellent insulator. Therefore our unipole insulated conductors guarantee utmost safety in operation.

The ground conductor is identified by international colour coding.

For obvious safety reasons phase and ground collectors are not interchangeable.

Any number of conductors can be accomplished by installing various powerails side by side. For extra space saving multiple compact hangers see page 15 and 29.

Standard rail sections are 6 m long, shorter lengths to coincide with your runway requirements are available.

Hangers

Support brackets will be prepared in accordance to your local requirements or provided by others considering your runway system configuration.

Rail holders

Spacing between rail holders is 1 m for U 20, 1.5 m for U 30 and 2 m for U 40 rails – in curves max. one half of these intervals.

Use insulated hangers or insulators with rail holders for all outdoor installations.

Accurate installation of the rail holders and hangers is important thus allowing the conductor rails to expand and contract. Anchor

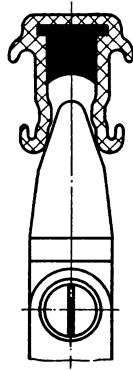

points are required to permanently fix, with respect to the runway track, the mid-point of the run or between adjacent expansion joints, in order to permit symmetrical expansion and contraction on both sides of the anchor point.

Insulators

Insulators are recommended for difficult environmental conditions (extreme humidity, chemicals etc.) See pages 14, 28, 39 for electrical and mechanical properties of our standard insulators. Further types, also for high voltage, are available upon request.

Rigid joints

Splice joints are designed to rigidly join conductor bars and provide mechanical and electrical continuity of the conductor rail system. They include insulated protection covers.

Expansion joints

In order to accommodate the effects of temperature change and for system runs exceeding 100 m (330') it is necessary to provide expansion joints.

Feed terminals

Feed terminal clamps are preferably installed at rail joints. Adequate single core feed cables shall be provided for connection of the incoming power to the conductor rails.

End caps

The open ends of unipole conductors are closed by end caps.

Collectors

The current collectors are made of reinforced polyamid and stainless steel parts. These spring loaded units provide positive contact with the conductor bars and have one or two pick up brushes.

Transfer guides

Unipole and multiple transfer guides are available for spurlines, turntables and switches or other transfer applications.

Isolating sections

Conductor isolating sections are available for sectionalizing control circuits, maintenance bays etc. (see pages 13, 27, 38).

Curves

Factory fabricated or field prepared radius bends can be used for horizontal or vertical curves.

Insulating covers

	Standard shrouding colour green	High temp. shrouding colour grey
Electrical properties:		
dielectric strength DIN 53 481	30-40 kV/mm	45 kV/mm
specific resistance DIN 53 482	5 x 10 ¹⁵ Ohm/cm	5 x 10 ¹⁷ Ohm/cm
surface resistance DIN 53 482	10 ¹³ Ohm	10 ¹⁵ Ohm
leakage resistance IEC 112 / VDE 0303	CTI 600-2.7	CTI 600-2.7
Mechanical properties:		
flexible strength	75 N/mm ² ± 10%	95 N/mm ² ± 10%
tensile strength	50 N/mm ² ± 10%	50 N/mm ² ± 10%
Temperature resistance:*	-30° C/ +55° C	-30° C/ +80° C
flame test proof per DIN 4102 part 1	class B1 no flaming particles, self extinguishing	

Resistance to chemicals for both covers:

Resistant to gasoline – mineral oil – grease – hydrochlorid acid (concentrated) – 50% sulfuric acid – 50% caustic soda.

Water absorption:

max. at 100° C – 1%
max. at 20° C – 0.06%

Please consult factory for galvanizing plants and pickling lines as well as low voltage applications, indicating special environmental data.

To speed up quotations and order processing, we would appreciate receiving your drawings or sketches for systems with curves, dead sections, turnables, switches etc.

Please use our questionnaire, pages 44/45.



The selection of conductors is determined from the nominal rated current of all motors working simultaneously on the system.

- Order:** **1. Determination of ampacity** **3. Control of voltage drop**
 2. Selection of conductors **4. Selection of current collectors**

As the premises and statements about output often differ, the following guidelines are to be considered:

Guidelines:	If the individual motor output is known:	↴	If only the total installed output per crane is known:	↴
		Calculation process No:		Calculation process No:
	Determining current:	1a), 1b), 1c)		1d), 1e)
	Voltage drop:	3a), 3b)		3a), 3c)
	Selection of current collector:	4a)		4b)

1. Determination of ampacity

a) Rated currents and starting currents of motors

Table 1:

Nominal output	Three-phase cage rotor (1500 U/min, 50 Hz)											Direct current motor			
	Efficiency	Power factors		Current								Efficiency	Motor current		
		$\cos \varphi_N$	$\cos \varphi_A$	230 V		400 V		500 V		660 V			110 V	220 V	440 V
P kW	η %			I_N A	I_A A	I_N A	I_A A	I_N A	I_A A	I_N A	I_A A	η %	I_N A	I_N A	I_N A
0.75	74.5	0.78	0.76	3.2	14.4	1.8	8.1	1.5	6.8	1.1	5	75	9.2	4.6	2.3
1.1	75	0.81	0.76	4.3	19.8	2.5	11.5	2	9.2	1.5	6.9	75	13.5	6.8	3.4
1.5	77	0.82	0.76	5.8	27.3	3.3	15.5	2.6	12.2	2	9.4	77	17.2	8.7	4.4
2.2	80	0.82	0.73	8.2	39.4	4.7	22.6	3.7	17.8	2.9	14	78	27	13.3	6.7
3	80	0.79	0.73	11.1	54.4	6.4	31.4	5	24.5	3.5	17.2	80	34	17	8.5
4	82	0.84	0.73	14.6	73	8.4	42	6.4	32	4.9	24.5	80	45	22	11
5.5	83	0.85	0.65	19.6	100	11.3	57.6	8.6	43.9	6.7	34.2	84	61	30	15.5
7.5	85	0.86	0.65	25.8	134.2	14.8	77	11.5	59.8	9	46.8	85	82	41	21
11	87	0.86	0.6	36.9	195.6	21.2	112.4	17	90.1	13	68.9	86	120	60	30
15	87	0.86	0.6	50	270	29	156.6	22.5	121.5	17.5	94.5	87	160	81	41
18.5	88	0.86	0.6	61	335.5	35	192.5	27	148.5	21	115.5	88	195	97	49
22	89	0.87	0.6	71	398	41	230	32	179	25	140	89	232	116	58
30	90	0.87	0.6	96	547	55	314	43	245	33	188	89	315	155	78
37	90	0.87	0.6	119	690	68	394	54	313	42	244	89	384	190	96
45	91	0.88	0.6	141	832	81	478	64	378	49	289	90	462	230	116
55	91	0.88	0.6	172	-	99	594	78	468	60	360	91	-	282	140
75	91	0.88	0.6	235	-	135	826	106	647	82	500	92	-	380	190
90	92	0.88	0.6	279	-	160	992	127	787	98	608	93	-	-	225
110	92	0.88	0.6	341	-	196	-	154	970	118	743	93	-	-	277
132	92	0.88	0.6	409	-	235	-	182	-	140	896	93	-	-	330
160	93	0.88	0.6	491	-	282	-	220	-	170	-	93	-	-	-

This table shows typical running values which should only be used if there are no other manufacturers instructions.

Directions:	Rated current: I_N	Cage rotor motors:	$X = 6$	$I_A = X \cdot I_N$
	Starting current: I_A	Slipping rotor motor:	$X = 2$	
		Frequency regulated drives:	$X = 1.5$	

If the required motor outputs are not listed in this table, then use formula according to section 1d).

b) Determining of the equivalent continuous currents (I_D) at a running period of < 100 % ED (duty cycle).

The rated currents (I_N) of the individual motors are multiplied by the reduction factor (f_{ED}) for the running period.

$$I_D = I_N \cdot f_{ED}$$

$$(P_D = P_N \cdot f_{ED})$$

Table 2: Reduction factor for the running period of the motors.

Running period ED	20%	30%	40%	50%	60%	80%	100%
Reduction factor f_{ED}	0.45	0.54	0.63	0.71	0.78	0.89	1



SELECTION OF CONDUCTORS

c) Determining the whole equivalent continuous current of the installation (I_{DA})

After determination of the sequence of motors with the strongest output (I_D), the amperages marked with an "X" plus basic loads for lighting and heating are added together (see table 3).

Table 3:

$$I_{DA} = \sum I_D + \sum I_G$$

No of Cranes	Highest Output motor I_D^*	2 nd strongest motor I_D^*	3 rd strongest motor I_D^*	4 th strongest motor I_D^*	Basic load of all cranes $\sum I_G$
1	X	X	-	-	X
2	X	X	X	-	X
3	X	X	X	-	X
4	X	X	X	X	X
5	X	X	X	X	X
Joint work two Cranes	X	X	X	X	X

* With double drives corresponding to $2 \cdot I_D$; lifting magnet and hoisting unit are counted as one joint drive.

d) Determining rated current (I_{NK}) if only the total output (overall capacity) of a crane is given.

For three-phase drive:

$$I_{NK} = \frac{P_K [kW] \cdot 1000}{\sqrt{3} \cdot U [V] \cdot \cos \varphi_N \cdot \eta}$$

For direct current drive:

$$I_{NK} = \frac{P_K [kW] \cdot 1000}{U [V] \cdot \eta}$$

Approximately: $\cos \varphi_N = 0,85$ $\eta = 0,85$ (efficiency)

e) Reduction factor (f_R) for frequency operation of one crane and simultaneity factor (f_G) for several cranes on one conductor line.

	f_R 1 crane	f_G 2 cranes	f_G 3 cranes	f_G 4 cranes and more
High frequency operation (bridgecranes for bulk material, production cranes)	0.9	0.9	0.8	0.7
Normal operation (container cranes, harbour cranes, overhead travelling cranes)	0.7	0.8	0.65	0.5
Small operation (storage cranes)	0.5	0.7	0.5	0.4

$$I_{DA} = I_{NK} \cdot f_R \text{ (with one crane)}$$

$$I_{DA} = I_{NK} \cdot f_R \cdot f_G \text{ (with several cranes)}$$

2. Selection of conductors

a) According to the calculated equivalent continuous current of the installation (I_{DA}) the appropriate conductor rail is selected from Table 4

$$I_{DA} \leq I_{zul. (Table)}$$

$I_{zul.} = \text{max. continuous ampacity}$

Table 4: Engineering data

Conductor rail Type	Conductor cross section mm ²			Leakage distance of shroud mm	Max. voltage V	continuous ampere capacity A at 35° C	Resistance Ohm/1000 m	Impedance Ohm/1000 m at 50 Hz
	Copper	Al	Steel					
U 20/ 50 AF		30	18	45	1000	60	0.938	0.954
U 20/ 50 CE	30		18	45	1000	60	0.587	0.612
U 20/ 50 AC	18	30		45	1000	120	0.483	0.600
U 20/ 50 C	50			45	1000	210	0.376	0.416
U 20/ 50 CH	50			45	1000	210	0.376	0.416
U 30/125 AC	18	110		90	1000	280	0.226	0.284
U 30/225 AC	18	210		90	1000	330	0.134	0.216
U 30/120 CE	100		18	100	1000	330	0.178	0.222
U 30/ 75 C	75			100	1000	280	0.238	0.280
U 30/100 C	100			105	1000	330	0.178	0.264
U 30/130 CH	130			95	1000	400	0.137	0.221
U 30/150 C	150			95	1000	440	0.126	0.219
U 30/200 C	200			90	1000	530	0.090	0.195
U 30/200 CH	200			90	1000	530	0.090	0.195
U 40/300 AC	50	250		130	1000	490	0.096	0.198
U 40/200 C	200			130	1000	600	0.089	0.170
U 40/300 C	300			135	1000	700	0.063	0.178
U 40/300 CH	300			130	1000	700	0.063	0.178
U 40/400 C	400			130	1000	860	0.047	0.168
U 40/400 CH	400			130	1000	860	0.047	0.168
U 40/500 C	500			125	1000	1000	0.038	0.161
U 40/500 CH	500			120	1000	1000	0.038	0.161
U 40/500 CHH	500			120	1000	1000	0.038	0.161

b) If the ambient temperature is above +35° C the max. conductor rail ampacity (I_{zul}) must be reduced with the derating factors from Table 5.

$$I_{zul UT} = I_{zul} \cdot f_T$$

Table 5: Derating factors

Ambient temperature °C	35	40	45	50	55	60	65	70	75	80	85
Correction factor f_T Standard shroud	1	0.95	0.89	0.84	0.77	–	–	–	–	–	–
Correction factor f_T High temp. shroud and current collector	1	0.97	0.94	0.90	0.87	0.83	0.79	0.75	0.71	0.66	0.61

$$I_{DA} \leq I_{zul UT}$$

3. Control of voltage drop for the starting current

a) The placing of the feed-in point can be determined according to local conditions, mostly at the end of the installation (end feed-in point).

If not specified otherwise, 3% voltage drop in the conductors is within the limits established by the motor manufacturers.

The conductor size and/or number of feed points should be increased or even booster cables should be used in parallel in case the drop is exceeding the limitations.

Effectice length (l):

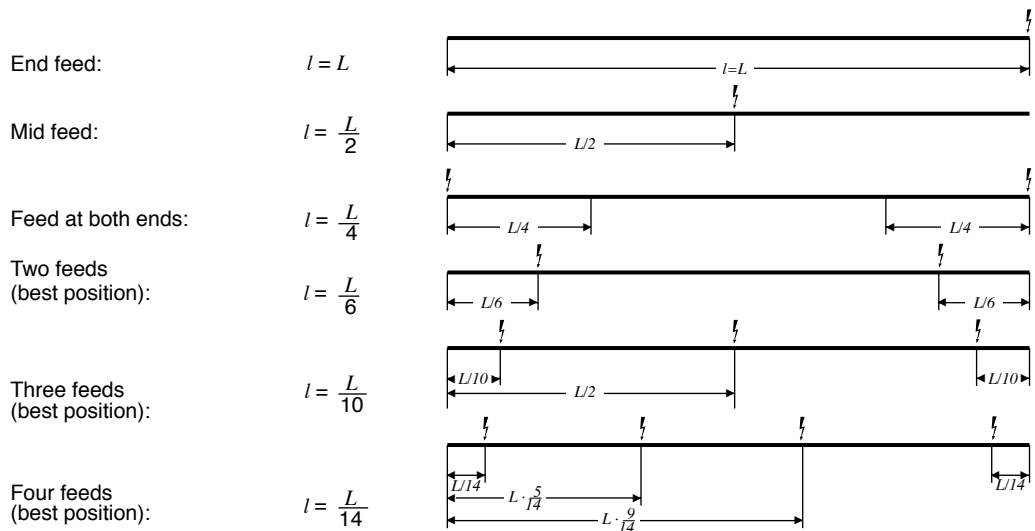

b) Determining of the maximum starting current of the installation (I_{AA}) if all individual outputs are known:

Table 6:

No of cranes	Of all cranes together (sequence acc. size of output)				Basic load of all cranes
	1. Motor	2. Motor	3. Motor	4. Motor	
1	I_A	I_N	–	–	ΣI_G
2	I_A	I_N	I_N	–	
3	I_A	I_N	I_N	I_N	
3*	I_A	I_A	–	–	
4	I_A	I_A	I_N	–	
5	I_A	I_A	I_N	I_N	

* At frequent or long starting processes

After the sequence has been determined, the amperages are added together.

$$I_{AA} = \Sigma I_A + \Sigma I_N + \Sigma I_G$$



SELECTION OF CONDUCTORS

c) Determining the maximum starting current (I_{AA}) if only the total of the installed crane capacity is available:

For the starting current use x-times of the amperage rating according to type of motor (see text for Table 1).

For one crane, or rather several cranes, at each time the crane with the strongest starting current applies.

- 1 Crane: $I_{AA} = I_{NK} \cdot X \cdot f_R$ f_R = Reduction factor (see 1 e)
- 2 Cranes: $I_{AA} = (I_{NK1} \cdot X + I_{NK2}) \cdot f_R$
- 3 Cranes: $I_{AA} = (I_{NK1} \cdot X + I_{NK2} + I_{NK3}) \cdot f_R$
- 4 Cranes: $I_{AA} = (I_{NK1} \cdot X + I_{NK2} + I_{NK3} + I_{NK4}) \cdot f_R$
- 5 Cranes: $I_{AA} = (I_{NK1} \cdot X + I_{NK2} + I_{NK3} + I_{NK4} + I_{NK5}) \cdot f_R$

d) Voltage Drop

At three-phase current:

$$\Delta U = \sqrt{3} \cdot l \cdot I_{AA} \cdot Z \cdot f_1$$

Z = Impedance of conductor line at UT = 20° C (see Table 4) [Ohm/1000 m]

At alternating current:

$$\Delta U = 2 \cdot l \cdot I_{AA} \cdot Z \cdot f_1$$

R = Resistance of conductor line at UT = 20° C (see Table 4) [Ohm/1000 m]

l = Feed length according to 3a)

At direct current:

$$\Delta U = 2 \cdot l \cdot I_{AA} \cdot R \cdot f_2$$

I_{AA} = Starting current in amps.

f_1, f_2 = Correction factors at UT > 20° C (see Table 7 & 8)

Table 7: f_1 (for $\cos\varphi = 0.6$; at three-phase and alternating current).

Ambient Temperature UT	Phase-Distance mm	25° C	30° C	35° C	40° C	45° C	50° C	55° C	60° C	65° C	70° C	75° C	80° C	85° C
U 20/50 AF	50	0.770	0.780	0.791	0.801	0.812	0.822	0.833	0.843	0.854	0.864	0.875	0.885	0.896
U 20/50 CE	50	0.878	0.889	0.900	0.911	0.922	0.933	0.944	0.955	0.966	0.977	0.988	0.999	1.010
U 20/50 AC	50	1.042	1.051	1.061	1.070	1.080	1.090	1.099	1.109	1.118	1.128	1.137	1.147	1.156
U 20/50 C	50	0.926	0.936	0.946	0.956	0.965	0.975	0.985	0.995	1.005	1.014	1.024	1.034	1.044
U 20/50 CH	50	0.926	0.936	0.946	0.956	0.965	0.975	0.985	0.995	1.005	1.014	1.024	1.034	1.044
U 30/125 AC	80	1.001	1.009	1.018	1.027	1.035	1.044	1.053	1.061	1.070	1.079	1.088	1.096	1.105
U 30/225 AC	80	1.024	1.031	1.037	1.044	1.051	1.057	1.064	1.071	1.077	1.084	1.091	1.097	1.104
U 30/120 CE	80	1.023	1.032	1.041	1.050	1.059	1.068	1.078	1.087	1.096	1.105	1.114	1.123	1.133
U 30/75 C	80	1.000	1.009	1.019	1.029	1.039	1.048	1.058	1.068	1.077	1.087	1.097	1.107	1.116
U 30/100 C	80	1.051	1.059	1.066	1.074	1.082	1.089	1.097	1.105	1.113	1.120	1.128	1.136	1.144
U 30/130 CH	80	1.050	1.058	1.065	1.072	1.079	1.086	1.093	1.100	1.107	1.114	1.121	1.129	1.136
U 30/150 C	80	1.024	1.030	1.036	1.043	1.049	1.055	1.061	1.067	1.074	1.080	1.086	1.092	1.099
U 30/200 C	80	1.021	1.026	1.032	1.037	1.042	1.047	1.052	1.058	1.063	1.068	1.073	1.079	1.084
U 30/200 CH	80	1.021	1.026	1.032	1.037	1.042	1.047	1.052	1.058	1.063	1.068	1.073	1.079	1.084
U 40/300 AC	130	1.010	1.016	1.021	1.026	1.031	1.037	1.042	1.047	1.052	1.058	1.063	1.068	1.073
U 40/200 C	130	1.039	1.045	1.051	1.057	1.063	1.069	1.075	1.081	1.087	1.093	1.099	1.105	1.111
U 40/300 C	130	0.976	0.979	0.983	0.987	0.991	0.995	0.999	1.002	1.006	1.010	1.014	1.018	1.021
U 40/300 CH	130	0.976	0.979	0.983	0.987	0.991	0.995	0.999	1.002	1.006	1.010	1.014	1.018	1.021
U 40/400 C	130	0.949	0.952	0.955	0.958	0.961	0.964	0.967	0.970	0.973	0.976	0.979	0.982	0.985
U 40/400 CH	130	0.949	0.952	0.955	0.958	0.961	0.964	0.967	0.970	0.973	0.976	0.979	0.982	0.985
U 40/500 C	130	0.928	0.931	0.933	0.936	0.938	0.941	0.943	0.946	0.949	0.951	0.954	0.956	0.959
U 40/500 CH	130	0.928	0.931	0.933	0.936	0.938	0.941	0.943	0.946	0.949	0.951	0.954	0.956	0.959
U 40/500 CHH	130	0.928	0.931	0.933	0.936	0.938	0.941	0.943	0.946	0.949	0.951	0.954	0.956	0.959

Table 8: f_2 (at direct current)

Ambient Temperature UT	Phase-Distance mm	25° C	30° C	35° C	40° C	45° C	50° C	55° C	60° C	65° C	70° C	75° C	80° C	85° C
U 20/50 AF	50	1.057	1.075	1.093	1.111	1.129	1.146	1.164	1.182	1.200	1.217	1.235	1.253	1.271
U 20/50 CE	50	1.133	1.152	1.171	1.190	1.209	1.228	1.247	1.266	1.285	1.304	1.324	1.343	1.362
U 20/50 AC	50	1.174	1.194	1.214	1.234	1.253	1.273	1.293	1.313	1.332	1.352	1.372	1.392	1.411
U 20/50 C	50	1.077	1.095	1.113	1.131	1.149	1.167	1.185	1.203	1.221	1.239	1.257	1.276	1.294
U 20/50 CH	50	1.077	1.095	1.113	1.131	1.149	1.167	1.185	1.203	1.221	1.239	1.257	1.276	1.294
U 30/125 AC	80	1.081	1.099	1.118	1.136	1.154	1.172	1.190	1.208	1.227	1.245	1.263	1.281	1.299
U 30/225 AC	80	1.065	1.083	1.101	1.119	1.137	1.155	1.173	1.191	1.209	1.227	1.245	1.262	1.280
U 30/120 CE	80	1.132	1.151	1.170	1.189	1.208	1.227	1.246	1.265	1.284	1.303	1.322	1.341	1.360
U 30/75 C	80	1.134	1.153	1.172	1.191	1.210	1.229	1.248	1.267	1.286	1.305	1.324	1.343	1.362
U 30/100 C	80	1.137	1.156	1.175	1.194	1.213	1.233	1.252	1.271	1.290	1.309	1.328	1.347	1.366
U 30/130 CH	80	1.136	1.155	1.175	1.194	1.213	1.232	1.251	1.270	1.289	1.308	1.327	1.346	1.366
U 30/150 C	80	1.071	1.089	1.107	1.125	1.143	1.161	1.179	1.197	1.215	1.233	1.251	1.269	1.287
U 30/200 C	80	1.124	1.143	1.162	1.181	1.200	1.219	1.238	1.257	1.276	1.294	1.313	1.332	1.351
U 30/200 CH	80	1.124	1.143	1.162	1.181	1.200	1.219	1.238	1.257	1.276	1.294	1.313	1.332	1.351
U 40/300 AC	130	1.068	1.086	1.104	1.122	1.140	1.158	1.176	1.194	1.212	1.230	1.248	1.266	1.284
U 40/200 C	130	1.137	1.156	1.175	1.194	1.213	1.233	1.252	1.271	1.290	1.309	1.328	1.347	1.366
U 40/300 C	130	1.071	1.089	1.107	1.125	1.143	1.161	1.179	1.197	1.215	1.233	1.251	1.269	1.287
U 40/300 CH	130	1.071	1.089	1.107	1.125	1.143	1.161	1.179	1.197	1.215	1.233	1.251	1.269	1.287
U 40/400 C	130	1.077	1.095	1.113	1.131	1.149	1.167	1.185	1.203	1.221	1.239	1.257	1.276	1.294
U 40/400 CH	130	1.077	1.095	1.113	1.131	1.149	1.167	1.185	1.203	1.221	1.239	1.257	1.276	1.294
U 40/500 C	130	1.065	1.083	1.101	1.119	1.137	1.155	1.173	1.191	1.208	1.226	1.244	1.262	1.280
U 40/500 CH	130	1.065	1.083	1.101	1.119	1.137	1.155	1.173	1.191	1.208	1.226	1.244	1.262	1.280
U 40/500 CHH	130	1.065	1.083	1.101	1.119	1.137	1.155	1.173	1.191	1.208	1.226	1.244	1.262	1.280



4. Selection of current collectors

For choosing the current collector consider the total ampacity (I_{DK}) reduced by the duty cycle.

a) When knowing each individual installed output according to 1 b) with one crane:

$$I_{DK} = \sum I_D$$

b) When knowing total installed output according to 1 d) and e) with one crane:

$$I_{DK} = I_{DA} = I_{NK} \cdot f_R$$

Select suitable current collectors in accordance to the ampere capacities shown in the catalogue.

c) If the ambient temperature is above +35° C, the permitted current collector load must also be reduced per correction factor (f_T) (Table 5).

Permitted current collector load

$$I_{zul UT} = I_{zul} \cdot f_T$$

I_{zul} = Continuous capacity as shown in the catalogue

5. Calculation example

2 overhead travelling cranes together on a conductor line of 180 m length.

Voltage 400 V, No. of feeds: 3

Squirrel-cage three-phase motors, maximum ambient temperature + 40° C

↪ For review two parallel calculation processes have been drawn up:

All individual output known:



Given:

Motor output (P_N)	Crane 1	Crane 2
Hoisting motor	110 kW, 60% ED	90 kW, 60% ED
Crane chassis	37 kW, 40% ED	22 kW, 40% ED
Cross traversing	30 kW, 40% ED	15 kW, 40% ED
Base load, lighting etc.	8 kW, 100% ED	4 kW, 100% ED

Only total installed output per crane known:



Installed total output (P_{NK})	Crane 1	Crane 2
	185 kW	131 kW

Determining of rated currents (I_N):

Either from Table 1 or with help of the formula:

$$I_N = \frac{P_N [kW] \cdot 1000}{\sqrt{3} \cdot U [V] \cdot \cos \varphi_N \cdot \eta}$$

	Crane 1	Crane 2
Hoisting motor	196 A	160 A
Crane chassis	68 A	41 A
Cross traversing	55 A	29 A
Base load	16 A	8 A

$$I_{NK1} = \frac{185 \text{ kW} \cdot 1000}{\sqrt{3} \cdot 400 \text{ V} \cdot \underbrace{0.85 \cdot 0.85}_{\text{assumed}}}$$

$$I_{NK1} = \underline{\underline{369.6 \text{ A}}}$$

$$I_{NK2} = \frac{131 \text{ kW} \cdot 1000}{\sqrt{3} \cdot 400 \text{ V} \cdot \underbrace{0.85 \cdot 0.85}_{\text{assumed}}}$$

$$I_{NK2} = \underline{\underline{261.7 \text{ A}}}$$

Ampacity reduced by the duty cycle factor (I_D):

$I_D = I_N \cdot f_{ED}$ (from Table 2)

	Crane 1	Crane 2
Hoisting motor	$I_D = 196 \text{ A} \cdot 0.73 = 143.1 \text{ A}$	$I_D = 160 \text{ A} \cdot 0.73 = 116.8 \text{ A}$
Crane chassis	$I_D = 68 \text{ A} \cdot 0.63 = 42.8 \text{ A}$	$I_D = 41 \text{ A} \cdot 0.63 = 25.8 \text{ A}$
Cross traversing	$I_D = 55 \text{ A} \cdot 0.63 = 34.7 \text{ A}$	$I_D = 29 \text{ A} \cdot 0.63 = 18.3 \text{ A}$
Base load	$I_D = 16 \text{ A} \cdot 1 = 16 \text{ A}$	$I_D = 8 \text{ A} \cdot 1 = 8 \text{ A}$
	$I_{DK1} = \underline{\underline{236.6 \text{ A}}}$	$I_{DK2} = \underline{\underline{168.9 \text{ A}}}$



SELECTION OF CONDUCTORS

Total equivalent continuous current of the installation (I_{DA}):

(According to Table 3: The three output-strongest motors plus base loads):

$$I_{DA} = \Sigma I_D + \Sigma I_G$$

$$I_{DA} = 143.1 \text{ A} + 116.8 \text{ A} + 42.8 \text{ A} + 16 \text{ A} + 8 \text{ A}$$

$$I_{DA} = \underline{\underline{326.7 \text{ A}}}$$

(With reduction factors and simultaneousness factors according to 1 e):

$$I_{DA} = (I_{NK1} + I_{NK2}) \cdot f_R \cdot f_G$$

$$I_{DA} = (369.6 \text{ A} + 261.7 \text{ A}) \cdot 0.7 \cdot 0.8$$

$$I_{DA} = \underline{\underline{354 \text{ A}}}$$

Selection of conductor:

U 30/200 C with $I_{zul} = 530 \text{ A}$ max. continuous current (Catalogue value at $UT = 35^\circ \text{ C}$)

With the ambient temperature of $+40^\circ \text{ C}$ a max. current load is calculated: (from Table 5)

$$I_{zul\ 40^\circ \text{ C}} = I_{zul} \cdot f_T = 530 \text{ A} \cdot 0.95$$

$$I_{zul\ 40^\circ \text{ C}} = \underline{\underline{504 \text{ A}}} > I_{DA}$$

Effective feed-in length with 3 feeds:

$$\text{Favourable arrangement: } l = \frac{L}{10} = \frac{180 \text{ m}}{10} = 18 \text{ m}$$

Max. starting current of the installation (I_{AA}):

The three strongest motors acc. to Table 6 (before values from Table 1) plus base loads

Size of output:

1. 110 kW $\rightarrow I_A = 1350 \text{ A}$
 2. 90 kW $\rightarrow I_N = 160 \text{ A}$
 3. 37 kW $\rightarrow I_N = 68 \text{ A}$
 4. Base load 1 $I_D = 20 \text{ A}$
 5. Base load 2 $I_D = 12 \text{ A}$
- $$I_{AA} = \underline{\underline{1610 \text{ A}}}$$

As no individual outputs are known, acc. to 3 c) with two cranes the following formula applies (strongest crane at the start):

$$I_{AA} = (I_{NK1} \cdot X + I_{NK2}) \cdot f_R \quad X = 6, \text{ because squirrel-cage motor}$$

$$I_{AA} = (369.6 \text{ A} \cdot 6 + 261.7) \cdot 0.7 \quad \text{ca. } I_A = 6 \cdot I_N$$

$$I_{AA} = \underline{\underline{1736 \text{ A}}}$$

Voltage drop:

$$\Delta U = \sqrt{3} \cdot l \cdot I_{AA} \cdot Z \cdot f_l$$

$$\Delta U = \sqrt{3} \cdot 18 \text{ m} \cdot 1610 \text{ A} \cdot \frac{0.195 \text{ Ohm}}{1000 \text{ m}} \cdot 1.037$$

$$\Delta U = \underline{\underline{10.2 \text{ V} \triangleq 2.5\% \text{ of } 400 \text{ V}}}$$

$$(f_l = 1.037 \text{ at } UT = 40^\circ \text{ C for U 30/200 C from Table 7})$$

$$\Delta U = \sqrt{3} \cdot 18 \text{ m} \cdot 1736 \text{ A} \cdot \frac{0.195 \text{ Ohm}}{1000 \text{ m}} \cdot 1.037$$

$$\Delta U = \underline{\underline{10.9 \text{ V} \triangleq 2.7\% \text{ of } 400 \text{ V}}}$$

The voltage drop is thus smaller than 3 % and the chosen current collector line sufficiently dimensioned.

Determining of current collector:

Crane 1:

$$I_{DK1} = \underline{\underline{236.6 \text{ A}}}$$

$$I_{DK1} = I_{NK1} \cdot f_R = 369.6 \text{ A} \cdot 0.7$$

$$I_{DK1} = \underline{\underline{258.7 \text{ A}}}$$

Current collector KDST 280/30 with $I_{zul} = 280 \text{ A}$ max. continuous current (Catalogue value at $UT = 35^\circ \text{ C}$)

For $UT = 40^\circ \text{ C}$:

$$I_{zul\ 40^\circ \text{ C}} = I_{zul} \cdot f_T$$

$$= 280 \text{ A} \cdot 0.97$$

$$I_{zul\ 40^\circ \text{ C}} = \underline{\underline{271 \text{ A}}}$$

$f_T = 0.97$ from Table 5

Crane 2:

$$I_{DK2} = \underline{\underline{168.9 \text{ A}}}$$

$$I_{DK2} = I_{NK2} \cdot f_R = 261.7 \text{ A} \cdot 0.7$$

$$I_{DK2} = \underline{\underline{183.2 \text{ A}}}$$

Current collector KDST 200/30 with $I_{zul} = 200 \text{ A}$ max. continuous current (Catalogue value at $UT = 35^\circ \text{ C}$)

For $UT = 40^\circ \text{ C}$:

$$I_{zul\ 40^\circ \text{ C}} = I_{zul} \cdot f_T$$

$$= 200 \text{ A} \cdot 0.97$$

$$I_{zul\ 40^\circ \text{ C}} = \underline{\underline{194 \text{ A}}}$$

$f_T = 0.97$ from Table 5

Type	U 20/50 AF	U 20/50 CE	U 20/50 AC	U 20/50 C	U 20/50 CH
Weight kg/m	0.350	0.500	0.400	0.580	0.560
Standard shrouding, color green					
Cat.-No. phase **	12700 •	12701 •	12702 •	12703 •	12704 •
Cat.-No. ground **	12710 •	12711 •	12712 •	12713 •	12714 •
High temperature shrouding, color grey					
Cat.-No. phase **	12705 •	12706 •	12707 •	12708 •	12709 •
Cat.-No. ground **	12715 •	12716 •	12717 •	12718 •	12719 •

Engineering data

Conductors Type	Conductor cross section mm ²			Leakage distance of shroud mm	Max. Voltage V	max. continuous ampere capacity A at 35° C	Resistance (R) Ohm/1000 m	Impedance Ohm/ 1000 m based on 50 Hz & 50 mm cond. spacing
	Copper	Alu- minium	Steel					
U 20/50 AF		30	18	45	1000	60	0.938	0.954
U 20/50 CE	30		18	45	1000	60	0.587	0.612
U 20/50 AC	18	30		45	1000	120	0.483	0.600
U 20/50 C	50			45	1000	210	0.376	0.416
U 20/50 CH	50			45	1000	210	0.376	0.416

Conductor code:

U = Unipole insulated conductor
 20 = Shroud size
 50 = Cross sectional area (mm²)
 AF = Aluminium/galvanized steel conductor
 CE = Copper/stainless steel conductor
 AC = Aluminium/copper conductor
 C = Copper conductor
 CH = Copper conductor with extra deep groove for high speed application and lateral mounting

Application:

Type AF not for corrosive environments
 Type CE, AC, C and CH for indoors and outdoors

Supply lengths:

6 m standard;
 shorter lengths are available

Support spacing:

– for straight runs and lateral curves: 1000 mm
 – for horizontal curves $R_H < 5$ m: 500 mm
 – for horizontal curves $R_H > 5$ m: 1000 mm

Bending:

Factory fabricated min. R = 400 mm
 Field fabrication min. R = 2500 mm

See page 4 for chemical and electrical properties

Rigid joints

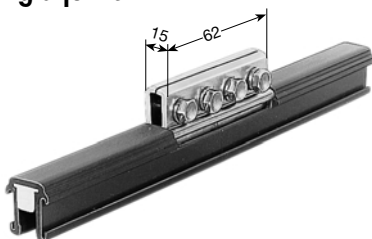

Type UVB – shown without cap

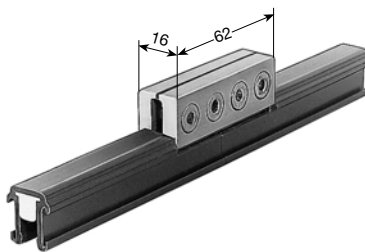

Type UV – shown without cap

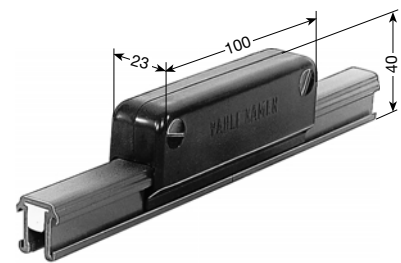

Type UVB 20 and UV 20

Type	for conductors			Weight kg	Cat.-No.
UVB 20/50	U 20/50 AF	U 20/50 CE		0.085	126 500
UVB 20/50 K 4*	U 20/50 AF	U 20/50 CE		0.085	126 502
UV 20/50	U 20/50 AC	U 20/50 C	U 20/50 CH	0.140	120 180
UV 20/50 K 4*	U 20/50 AC	U 20/50 C	U 20/50 CH	0.140	126 504

* Stainless steel hardware

** Add last number (1, 2, 3, 4, 5 or 6 m length suffix) in accordance to bars required.



ACCESSORIES FOR U 20

Expansion sections

factory assembled to 1 m long conductor section, incl. one rigid joint.
The one meter expansion assembly is part of the system length.

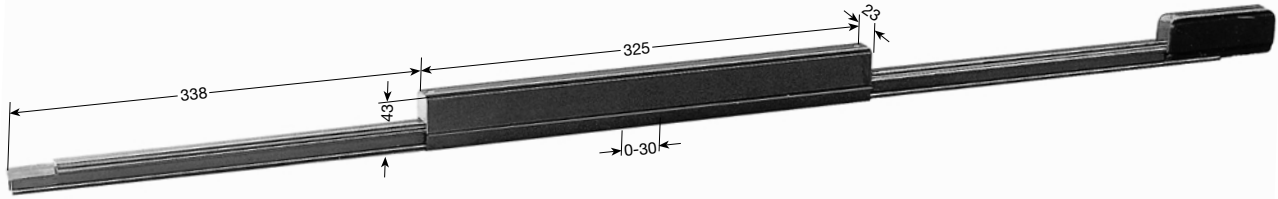

Standard shrouding, color green

Type	Weight kg	Cat.-No.	
		phase	ground
UDV 20/50 AF K 4*	0.525	126 512	126 513
UDV 20/50 CE K 4*	0.622	126 514	126 515
UDV 20/50 AC K 4*	0.622	126 516	126 517
UDV 20/50 C K 4*	1.030	126 518	126 519
UDV 20/50 CH K 4*	1.020	126 520	126 521

High temperature shrouding, colour grey

Type	Weight kg	Cat.-No.	
		phase	ground
UDV 20/50 AF K 4*	0.525	126 672	126 673
UDV 20/50 CE K 4*	0.622	126 674	126 675
UDV 20/50 AC K 4*	0.622	126 676	126 677
UDV 20/50 C K 4*	1.030	126 678	126 679
UDV 20/50 CH K 4*	1.020	126 680	126 681

Feed terminals

Type	Weight kg	Cat.-No.
UE 20/50	0.290	120 220
UE 20/50 K 4*	0.290	126 522

To be used instead of rigid joints
Feed cable: 2 of max. 50 mm²

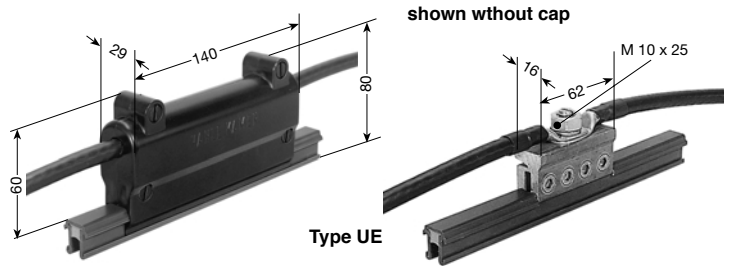

Type	Weight kg	Cat.-No.
UEN 20/50 K 4*-A	0.120	126 526
UEN 20/50 K 4*-B	0.120	120 116

Feed cable: 1 of max. 6 mm²

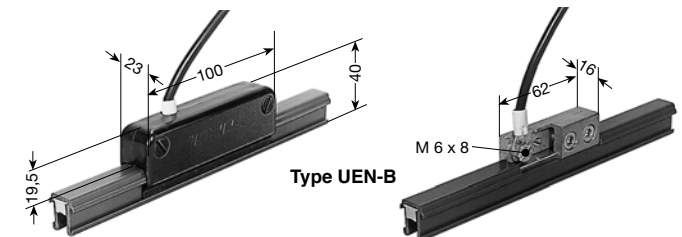
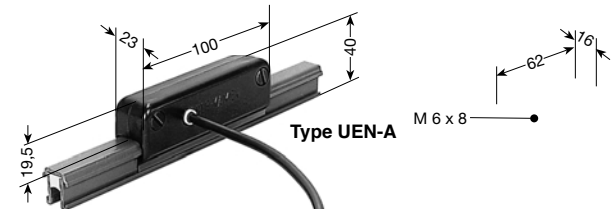

Type	Weight kg	Cat.-No.
UES 20/50 K 4*	0.060	126 530

Feed cable: 1 of max. 4 mm²

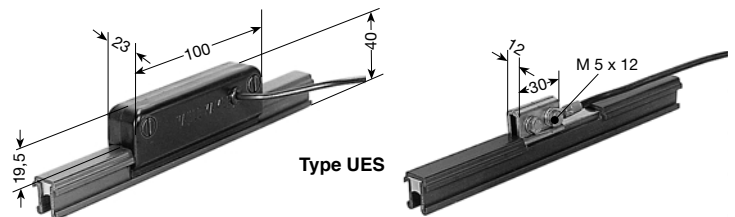

Contact Paste for joints and feeds

20 Grams for ca. 40 joints	Cat.-No. 120 016
500 Grams for ca. 1000 joints	Cat.-No. 120 017



Transfer funnels

Transfer funnels will be required in conjunction with spur lines, switches and turntables.

Consult factory for details, indicating type of rail, number of conductors, position of ground etc. within your system.

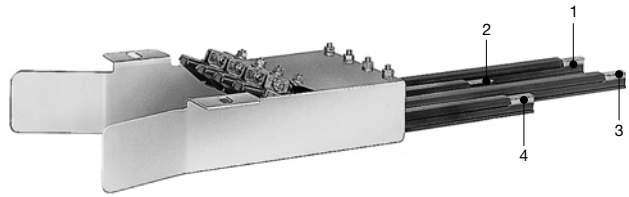

Type EM 20

Transfer guides

These guides serve for transfer or power interrupting-applications.

Max. horizontal and vertical offset: ± 2 mm; gap between two transfer guides max. 8 mm.

Extra hangers are required and to be ordered separately.

Type	for conductors	Wght. kg	Cat.-No.
US 20/50 CH K 4*	U 20/50 CH	0.046	120 849
US 20/50 C K 4*	U 20/50 C	0.046	120 848
US 20/50 A K 4*	U 20/50 AC	0.046	120 847
	U 20/50 AF		
	U 20/50 CE		

Transfer guides US 20 are fastened to conductor ends by means of one nylon screw.

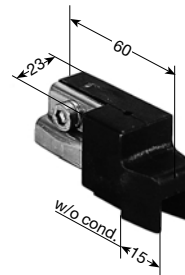

Isolating sections

Type M: Factory assembled per system layout

Type L: Loose, incl. 2 locking pins 3 x 10

Use one extra hanger each side, max. 200 mm away for stability.

Rails & hangers to be ordered separately

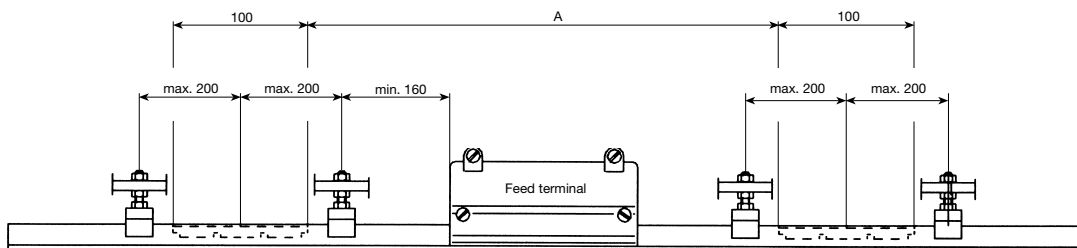
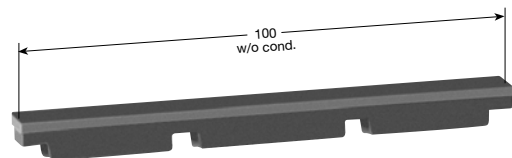

To avoid voltage by-pass by carbon brushes and to separate maintenance bays, control and main feed sections, double isolating sections are recommended.

Dim. **A** depends on type and number of current collectors and stopping distance of the crane.

Type	for conductors	Wght kg	Cat.-No.
IT/U 20/50 CH-M	U 20/50 CH	0.005	120 950
IT/U 20/50 C -M	U 20/50 C	0.005	120 940
IT/U 20/50 A C-M	U 20/50 AC	0.005	126 536
	U 20/50 AF		
	U 20/50 CE		

Typ	for conductors	Wght kg	Cat.-No.
IT/U 20/50 CH-L	U 20/50 CH	0.005	120 010
IT/U 20/50 C -L	U 20/50 C	0.005	120 009
IT/U 20/50 A -L	U 20/50 AC	0.005	120 008
	U 20/50 AF		
	U 20/50 CE		

* with stainless steel hardware



ACCESSORIES FOR U 20

Locating clamp



Fixpoint (insulated rail holder with 2 locating clamps)

Type	Weight kg	Cat.-No.
USK 20 K 4*	0.028	120 140

Insulated rail holders**

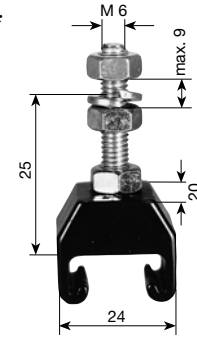

Type	Weight kg	Cat.-No.
UAM 20	0.025	126 540
UAM 20 K 4*	0.025	126 542

Insulators

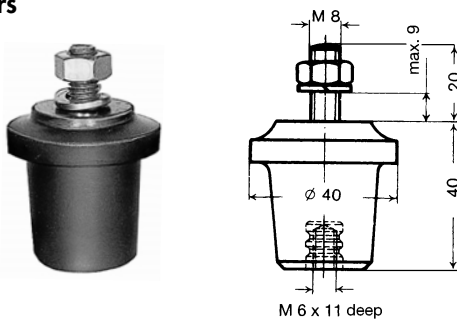

Cantilever strength = 3000 N
Leakage distance = 60 mm

Type	Weight kg	Cat.-No.
GH 40-M 6	0.075	121 060
GH 40-M 6 K 4*	0.075	126 544

Insulator**

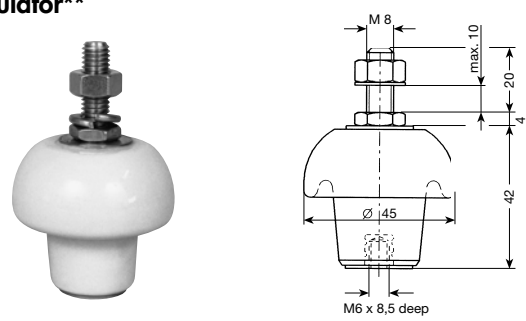

cantilever strength = 1000 N
Leakage distance = 62 mm

Type	Weight kg	Cat.-No.
UIK 42-M 6 K 4	0.110	120 883

Rail holders

to go with insulators



Supplied with bolt M 6 x 12

Type	Weight kg	Cat.-No.
UAK 20	0.010	126 546
UAK 20 K 4*	0.010	126 548

Supplied with bolt M 6 x 10 and spring washer

Type	Weight kg	Cat.-No.
UAS 20 K 4*	0.014	126 550

End caps

L = loose, incl. locking hardware
M = factory assembled



Type	Weight kg	Cat.-No.
UK 20-L	0.010	120 120
UK 20-M	0.010	120 987



4pole insulated conductor rail arrangement

* Stainless steel hardware
** Suspension in slotted holes requires 2 off washers 6,4



Any number of conductors can be assembled by cutting/combining the compact hangers.
Use collectors of series KST only. Joints and feed terminals must be mounted staggered by 200 mm.

Compact hanger, 5 pole for direct bolting
to support structure**

Type	Weight kg	Cat.-No.
KA 20/5	0.041	126 613

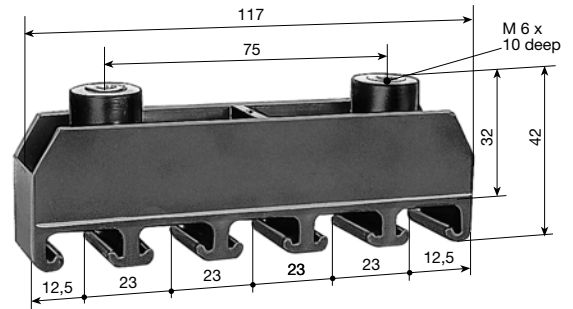

Compact hangers, 5 pole to go with bracket profile 38/17 G

Type	Weight kg	Cat.-No.
KH 20/5-3	0.032	126 614
KH 20/5-4	0.049	126 615
KH 20/5-5	0.054	126 616

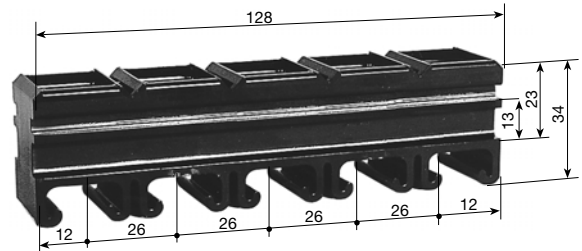

Further compact hangers and for more conductors on request.

Attachment hardware for KA hangers

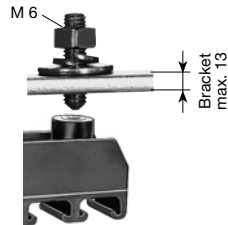

Type	Weight kg	Cat.-No.
Hardware BE 6	0.015	120 406
Hardware BE 6 K 4*	0.015	120 778

Flat washers

(required on both sides of brackets with slotted holes)

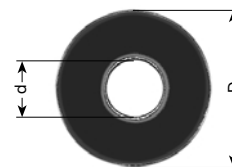

Type	Thread	d mm	D mm	S mm	Weight kg	Cat.-No.
Washer 6,4	M 6	6.4	18	1.6	0.003	120 776
Washer 6,4 K 4*	M 6	6.4	18	1.6	0.003	120 777

Bracket profiles 38/17

incl. locking hardware

Type	Length mm	Max. poles	Weight kg	Cat.-No.
HU 20/230	230	5	0.400	120 833
HU 20/360	360	10	0.750	120 834
HU 20/490	490	15	0.970	120 835

Longer Bracket profiles on request.

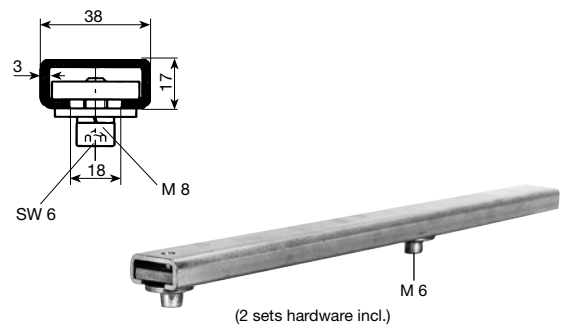

* Stainless steel hardware.

** Suspension in slotted holes requires 2 off washers 6,4.



CURRENT COLLECTORS FOR U 20

Current collectors

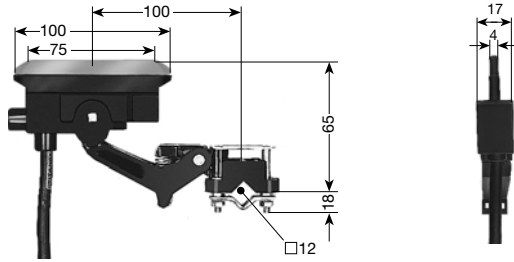

with 2 m connecting cable
lift and swivel ± 20 mm
contact pressure: ~ 9 N

Double collectors

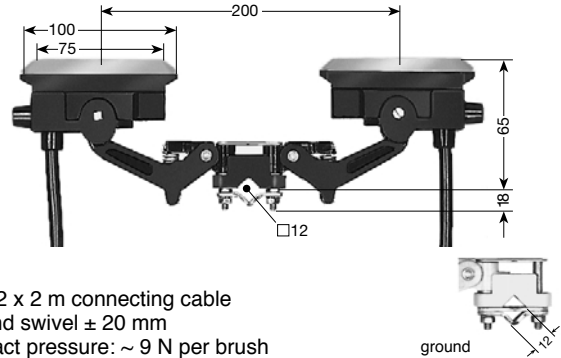

with 2 x 2 m connecting cable
lift and swivel ± 20 mm
contact pressure: ~ 9 N per brush

Type	Am- pacity A*	Connecting cable		Weight kg	Cat.-No.		Type	Am- pacity A*	Connecting cable		Weight kg	Cat.-No.	
		mm ²	ø max. mm		phase black	ground yellow			mm ²	ø max. mm		phase black	ground yellow
KST 15	15	2.5	4.4	0.256	150 891	150 892	KDST 30	30	2.5	4.4	0.471	150 897	150 898
KST 40	40	6.0	11.0	0.428	152 840	152 850	KDST 80	80	6.0	11.0	0.821	152 960	152 970
KST 60	60	10.0	12.5	0.588	153 675	153 676	KDST 120	120	10.0	12.5	1.114	153 679	153 680

Current collectors

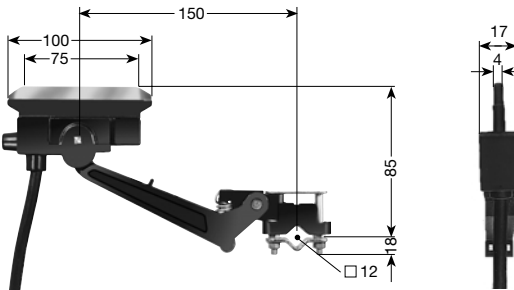

with 2 m connecting cable
lift and swivel ± 40 mm
contact pressure: ~ 9 N

Double collectors

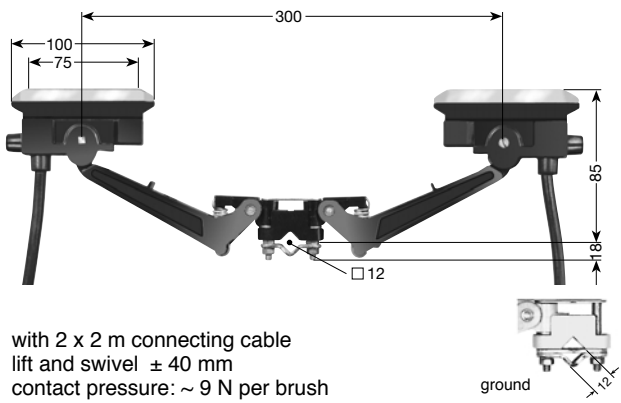

with 2 x 2 m connecting cable
lift and swivel ± 40 mm
contact pressure: ~ 9 N per brush

Type	Am- pacity A*	Connecting cable		Weight kg	Cat.-No.		Type	Am- pacity A*	Connecting cable		Weight kg	Cat.-No.	
		mm ²	ø max. mm		phase black	ground yellow			mm ²	ø max. mm		phase black	ground yellow
KSTL 15	15	2.5	4.4	0.272	150 893	150 894	KDSTL 30	30	2.5	4.4	0.492	150 899	150 901
KSTL 40	40	6.0	11.0	0.453	152 860	152 870	KDSTL 80	80	6.0	11.0	0.822	152 980	152 990
KSTL 60	60	10.0	12.5	0.591	153 677	153 678	KDSTL 120	120	10.0	12.5	1.188	153 681	153 682

Current collectors for transfer funnels EMK

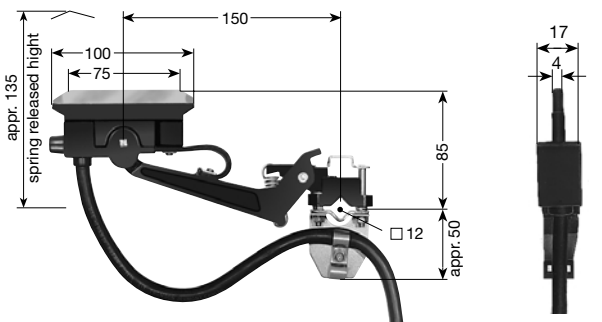

with 2 m connecting cable
lift ± 20 mm
swivel ± 40 mm
contact pressure: ~ 9 N

Double collectors for transfer funnels EMK

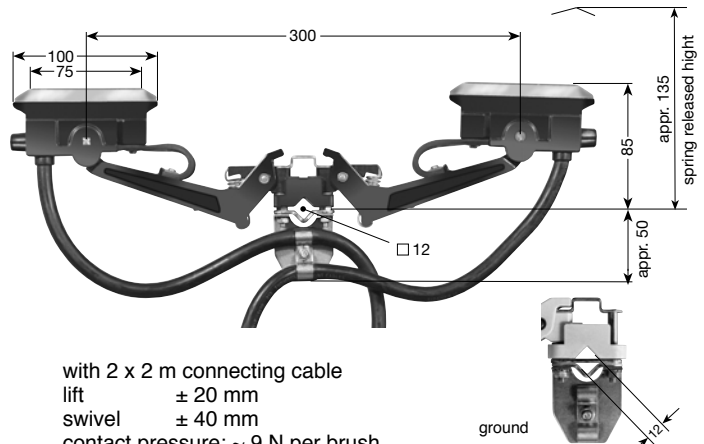

with 2 x 2 m connecting cable
lift ± 20 mm
swivel ± 40 mm
contact pressure: ~ 9 N per brush

Type	Am- pacity A*	Connecting cable		Weight kg	Cat.-No.		Type	Am- pacity A*	Connecting cable		Weight kg	Cat.-No.	
		mm ²	ø max. mm		phase black	ground yellow			mm ²	ø max. mm		phase black	ground yellow
KSTLU 15	15	2.5	4.4	0.313	150 895	150 896	KDSTLU 30	30	2.5	4.4	0.541	150 902	150 903
KSTLU 40	40	6.0	11.0	0.499	153 791	153 792	KDSTLU 80	80	6.0	11.0	0.895	153 786	153 787
KSTLU 60	60	10.0	12.5	0.652	153 793	153 794	KDSTLU 120	120	10.0	12.5	1.231	153 795	153 796

Current collectors

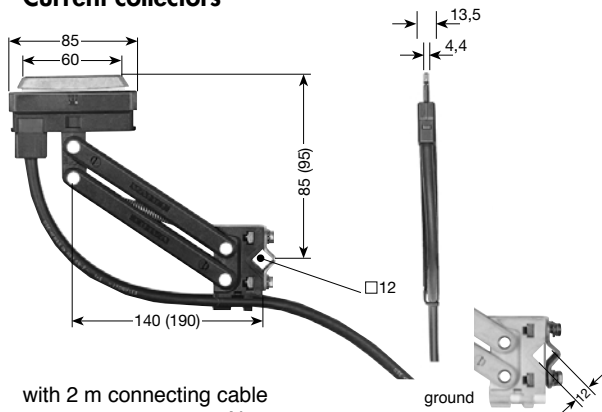

with 2 m connecting cable
contact pressure: ~ 5 N

Type	Am- pacity A*	Connecting cable		lift & swivel mm	Weight kg	Cat.-No.	
		mm ²	ø max. mm			phase black	ground yellow
KST 30	30	2.5	5	± 20	0.240	152 085	152 086
KST 55	55	6.0	11	± 20	0.368	154 438	154 439
KSTL 30	30	2.5	5	± 30	0.240	152 089	152 091
KSTL 55	55	6.0	11	± 30	0.368	154 443	154 444

Dimensions in parenthesis for KSTL

Current collectors **

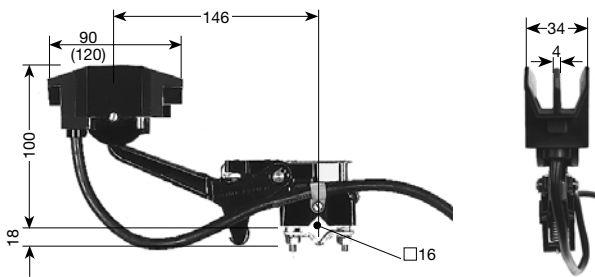

with 2 m connecting cable
lift ± 25 mm
swivel ± 30 mm
contact pressure: ~ 10 N

Double collectors **

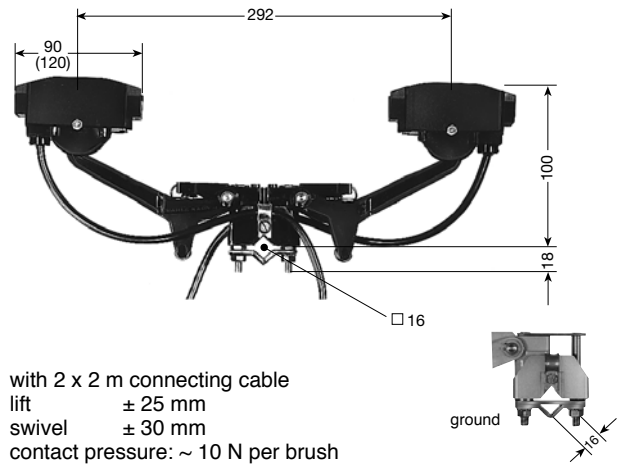

with 2 x 2 m connecting cable
lift ± 25 mm
swivel ± 30 mm
contact pressure: ~ 10 N per brush

Type	Am- pacity A*	Connecting cable		Weight kg	Cat.-No.		Type	Am- pacity A*	Connecting cable		Weight kg	Cat.-No.	
		mm ²	ø max. mm		phase black	ground yellow			mm ²	ø max. mm		phase black	ground yellow
UST 40	40	6	11.0	0.605	120 961	120 962	UDST 80	80	6	11.0	1.100	120 965	120 966
UST 60	60	10	12.5	0.875	120 963	120 964	UDST 120	120	10	12.5	1.600	126 967	120 968

Dimension in parenthesis for UST 60

Dimension in parenthesis for UDST 120

Current collector for transfer funnels EM **

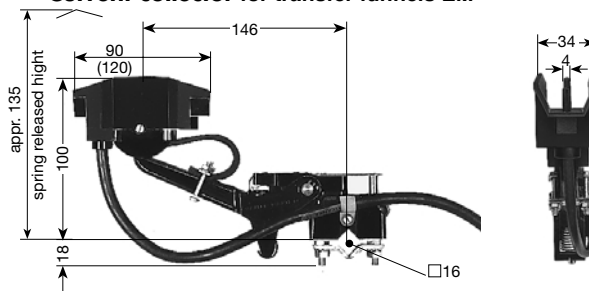

with 2 m connecting cable
lift ± 25 mm
swivel ± 30 mm
contact pressure: ~ 10 N

Double collector for transfer funnels EM **

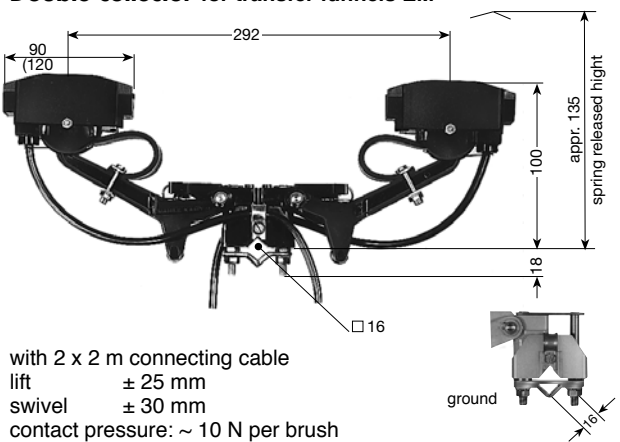

with 2 x 2 m connecting cable
lift ± 25 mm
swivel ± 30 mm
contact pressure: ~ 10 N per brush

Type	Am- pacity A*	Connecting cable		Weight kg	Cat.-No.		Type	Am- pacity A*	Connecting cable		Weight kg	Cat.-No.	
		mm ²	ø max. mm		phase black	ground yellow			mm ²	ø max. mm		phase black	ground yellow
USTU 40	40	6	11.0	0.635	120 969	120 970	UDSTU 80	80	6	11.0	1.160	120 973	120 974
USTU 60	60	10	12.5	0.815	126 971	126 972	UDSTU 120	120	10	12.5	1.550	126 975	126 976

Dimension in parenthesis for USTU 60

Dimension in parenthesis for UDSTU 120

* Reduced ampacity when using rail type U 20/50 CE – consult factory

** For 50 mm phase distance only



COLLECTOR COMPONENTS U 20

Collector bracket for KST and UST

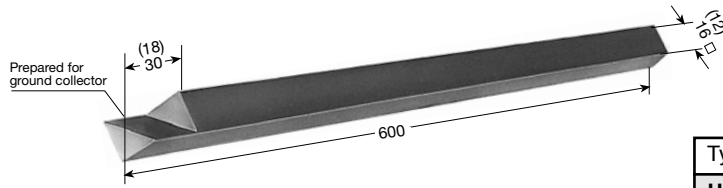

Dimensions in parenthesis for UM 12

Type	Weight kg	Cat.-No.
UM 12 (for KST)	0.675	153 506
UM 16 (for UST)	1.175	126 574

Longer brackets furnished on special order.

In this case an extra support is to be provided to avoid bending or twisting of the collector bracket.

Collector brackets

for current collectors
KST / KDST see page 16

for current collectors
KST 30 - 55 see page 17

for control collectors

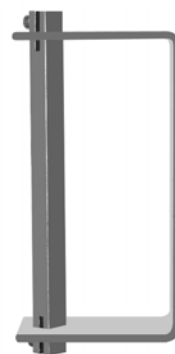
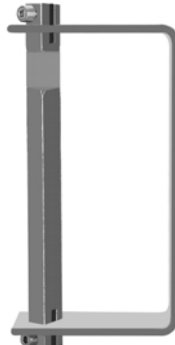
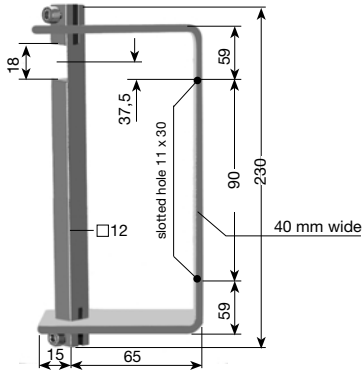

Type	Weight kg	Cat.-No.
UMAS 12 HS-A 200	0.740	121 092

Type	Weight kg	Cat.-No.
UMAS 12 HS-B 200	0.740	121 093

Type	Weight kg	Cat.-No.
UMAS 12 ST 200	0.740	121 094

Suitable for phase distance of max. 55 mm (3 pole + ground).

Tension springs (stainless steel)

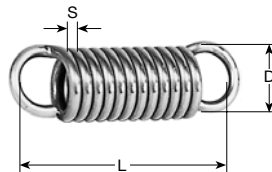

Type	for current collectors	Weight kg	S mm	D mm	L mm	Cat.-No.
ZF 3	KST 15 thru KDST 120	0.003	1.1	10.8	28.5	153 516
ZF 4	KSTL 15 thru KDSTL 120 and KSTLU 15 thru KDSTLU 120	0.004	1.3	11.0	29.0	153 517
ZF 5	UST 40, USTU 40, UDST 80, UDSTU 80 UST 60, USTU 60, UDST 120, UDSTU 120	0.007	1.5	13.8	40.0	126 585

Copper-graphite brushes

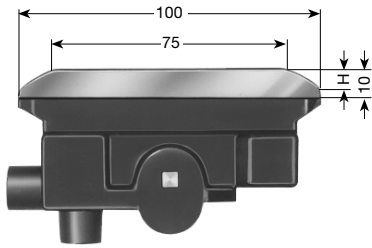

KMK 60

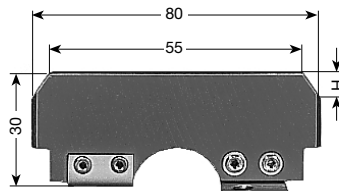

KMU 40

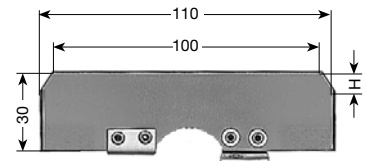

KMU 60

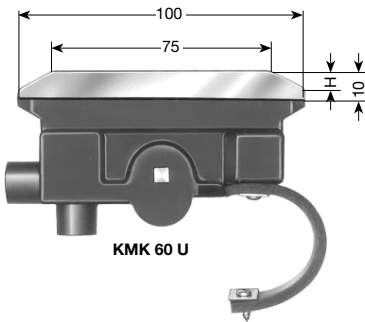

KMK 60 U

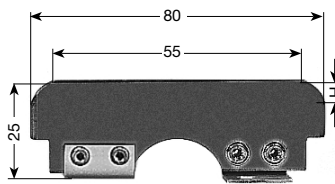

KMU 40 U

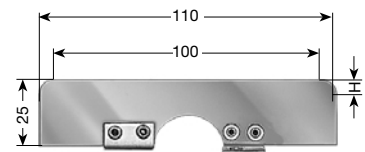

KMU 60 U

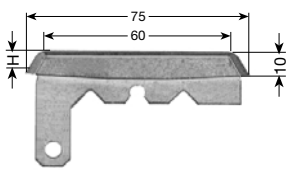

KMK 30- 55 PH

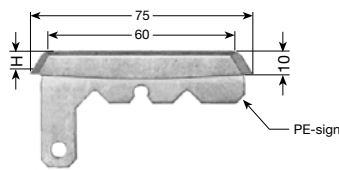

KMK 30- 55 PE

Dim H: max. wear for U 20/50 C

Type	for current collectors	H mm	Weight kg	Cat.-No.
KMK 60	KST 15, KST 40, KDST 30, KDST 80, KSTL 15, KSTL 40, KDSTL 30, KDSTL 80, KST 60, KDST 120, KSTL 60, KDSTL 120	7	0.110	153 512
KMK 60 U	KSTLU 15, KSTLU 40, KSTLU 60, KDSTLU 30, KDSTLU 80, KDSTLU 120	7	0.115	153 513
KMU 40	UST 40, UDST 80	9	0.060	126 579
KMU 40 U	USTU 40, UDSTU 80	4	0.050	126 696
KMU 60	UST 60, UDST 120	9	0.070	126 581
KMU 60 U	USTU 60, UDSTU 120	4	0.060	126 743
KMK 30-55, Phase	KST 30, KST 55, KSTL 30, KSTL 55	10	0.031	154 440
KMK 30-55, PE	KST 30, KST 55, KSTL 30, KSTL 55	10	0.031	154 453

Cable attachment clamp for current collectors Type KSTLU, KDSTLU

Type	Weight kg	Cat.-No.
KBK	0.030	153 519

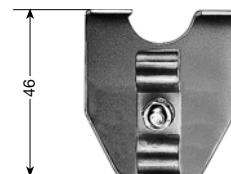



COLLECTOR COMPONENTS U 20

for Collector series KST, KSTL, KDST, KDSTL, KSTLU and KDSTLU

Part-No.	Description		Weight kg	Cat.-No.
1	Brush (see page 19)		–	–
2	Collector base for KST 15 thru KST 60	phase	0.080	153 736
3		ground		
2	Collector base for KDST 30 thru KDST 120	phase	0.100	153 738
3		ground		
2	Collector base for KSTL 15 thru KSTL 60	phase	0.090	153 740
3		ground		
2	Collector base for KSTLU 15 thru KSTLU 60	phase	0.090	153 804
3		ground		
2	Collector base for KDSTL 30 thru KDSTL 120	phase	0.130	153 742
3		ground		
2	Collector base for KDSTLU 30 thru KDSTLU 120	phase	0.130	153 806
3		ground		
4	Tension spring (see page 18)		–	–
5	Connecting cable AEA 2,5 PH, 2 m long Connecting cable AEA 2,5 PE, 2 m long	phase	0.072	151 374
		ground		
5	Connecting cable AEA 6 PH, 2 m long Connecting cable AEA 6 PE, 2 m long	phase	0.260	153 744
		ground		
5	Connecting cable AEA 10 PH, 2 m long Connecting cable AEA 10 PE, 2 m long	phase	0.400	153 746
		ground		
6	Rubber spring* for KSTLU 15, KSTLU 40, KSTLU 60, KDSTLU 30, KDSTLU 80, KDSTLU 120		0.008	153 748

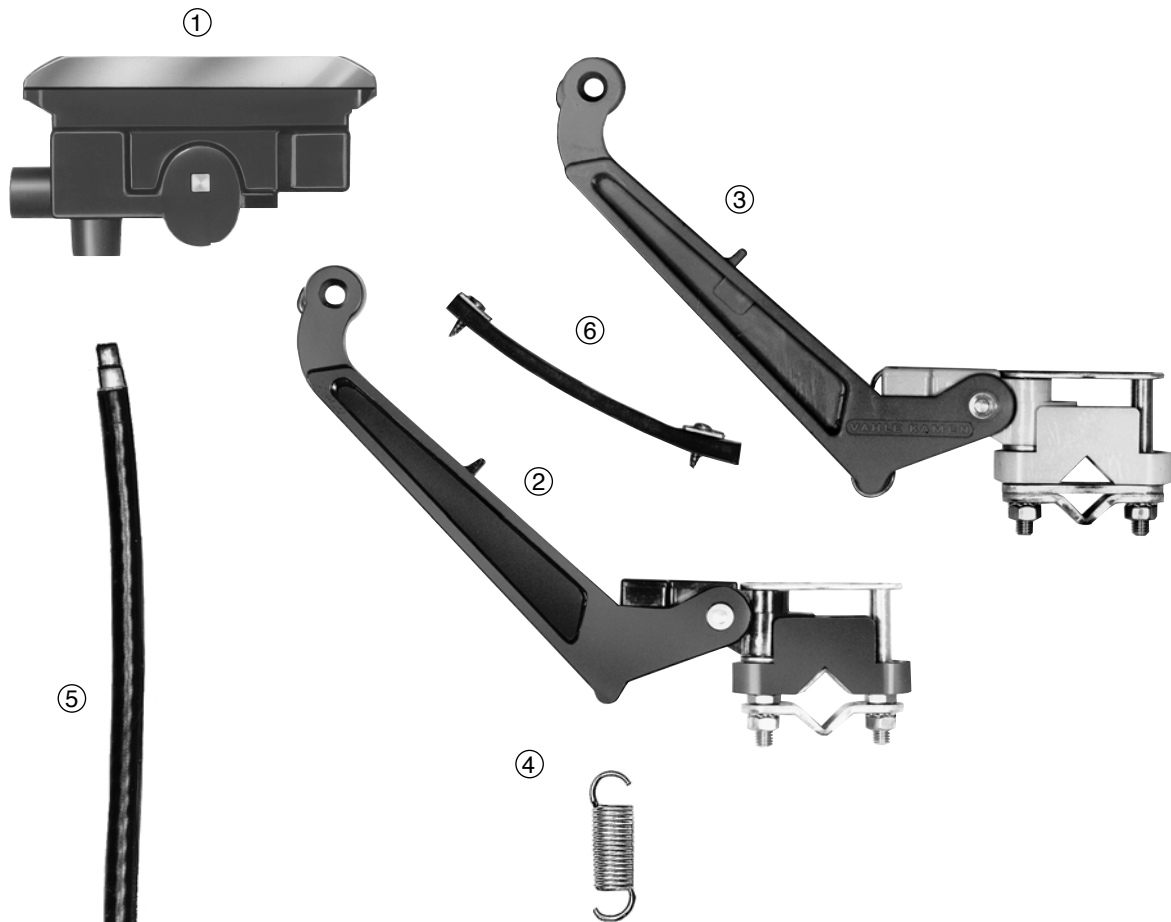



Collector series KST 30-55 thru KSTL 30-55

Part-No.	Description		Weight kg	Cat.-No.
1	Brush (see page 19)	phase	–	–
2	Brush (see page 19)	ground	–	–
3	Collector base & arm KST, complete	phase	0.083	152 654
4	Collector base & arm KST, complete	ground	0.083	152 655
3	Collector base & arm KSTL, complete	phase	0.083	152 656
4	Collector base & arm KSTL, complete	ground	0.083	152 657
5	Terminal cap	phase (black)	0.002	152 291
6	Terminal cap	ground (green)	0.002	152 292
7	Connecting cable RKA 2,5 PH, 2 m long	phase	0.150	154 447
	Connecting cable RKA 2,5 PE, 2 m long	ground	0.150	154 448
7	Connecting cable RKA 6 PH, 2 m long	phase	0.260	154 449
	Connecting cable RKA 6 PE, 2 m long	ground	0.260	154 450
8	Terminal bolt M 5 x 7 K 4		0.002	152 658

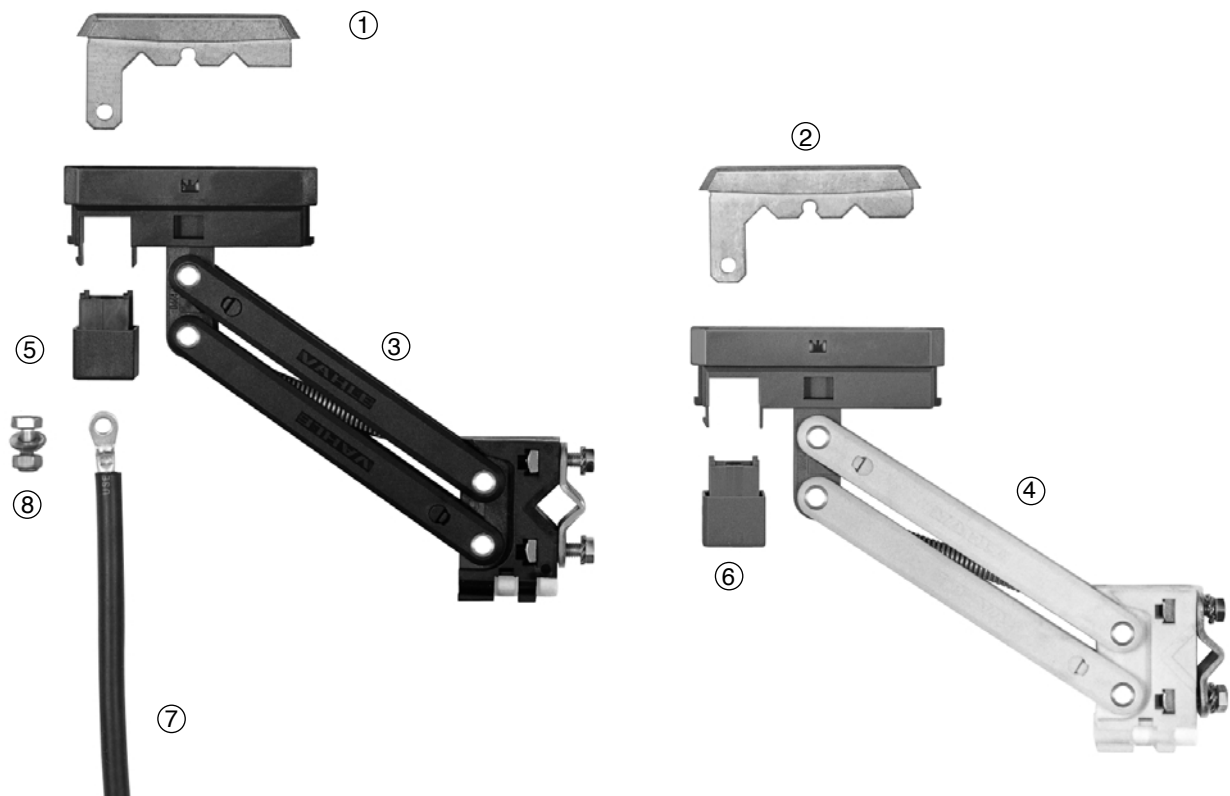



COLLECTOR COMPONENTS U 20

Collector series UST and UDST

Part-No.	Description	Weight kg	Cat.-No.
1	Brush (see page 19)		
2	Brush holder for UST 40, UDST 80, USTU 40, UDSTU 80	0.050	120 949
2	Brush holder for UST 60, UDST 120, USTU 60, UDSTU 120	0.070	120 941
3	Collector base		
4	for UST 40, UST 60	phase ground	126 604 126 605
3	Collector base		
4	for UDST 80, UDST 120	phase ground	126 692 126 693
3	Collector base		
4	for USTU 40, USTU 60	phase ground	126 606 126 607
3	Collector base		
4	for UDSTU 80, UDSTU 120	phase ground	126 694 126 695
5	Connecting cable 6 mm ² , 2 m long, for UST 40, USTU 40, UDST 80, UDSTU 80	phase ground	0.300 120 948 120 952
5	Connecting cable 10 mm ² , 2 m long, for UST 60, USTU 60, UDST 120, UDSTU 120	phase ground	0.445 120 939 120943
6	Connecting piece	0.030	120 946
7	Current bridge	0.010	120 947
8	Rubber spring complete for USTU 40, UDSTU 80, USTU 60, UDSTU 120	0.008	126 612
9	Tension spring (see page 18)	–	–

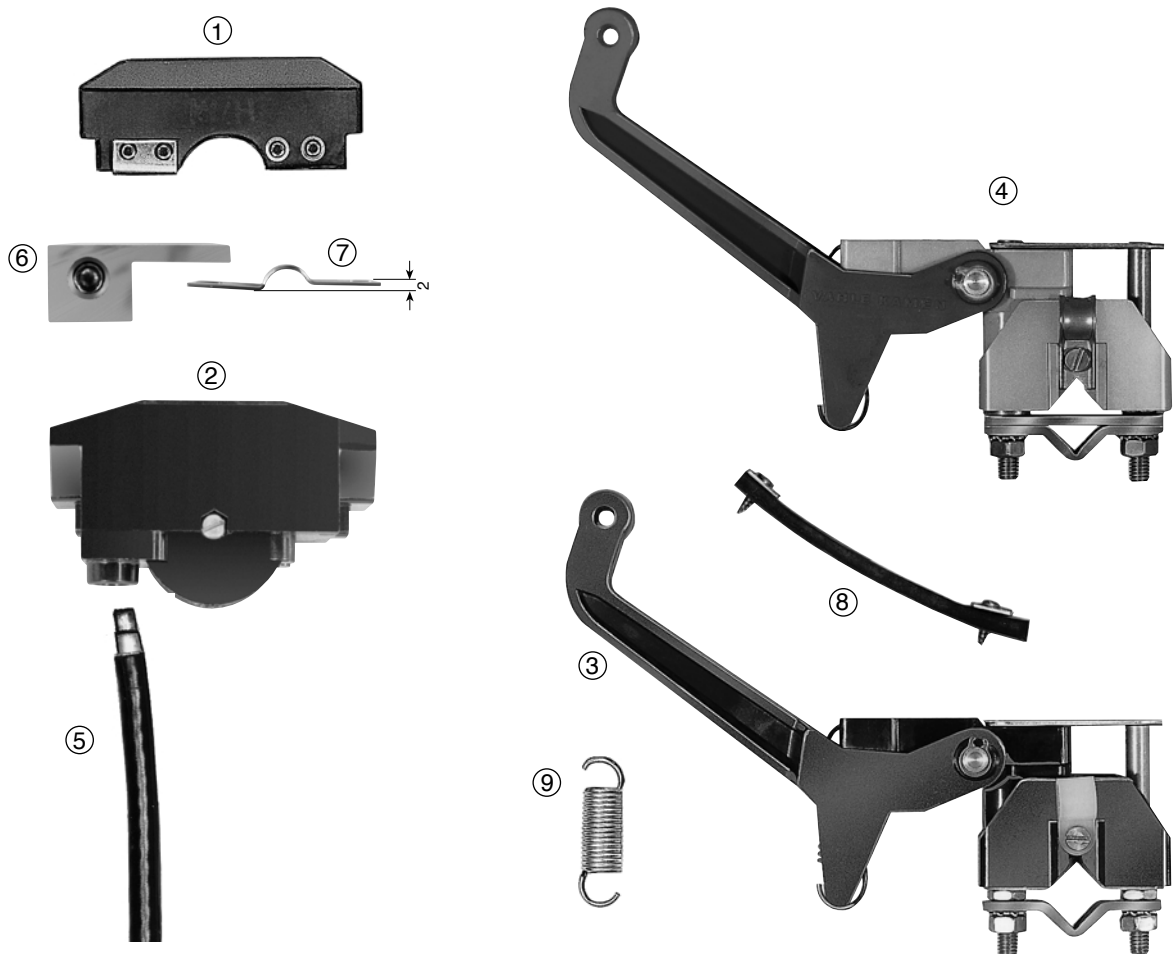

EXAMPLE FOR ORDERING U 20



Compact configuration, 31 m power supply system, 4 pole + ground, 120 A

	Qty.	Description	Type	Cat.-No.
	20	VAHLE unipole insulated conductors, 6 m long phase	U 20/50 AC-6	127 026
	4	VAHLE unipole insulated conductors, 1 m long phase	U 20/50 AC-1	127 021
	5	VAHLE unipole insulated conductors, 6 m long ground	U 20/50 AC-6	127 126
	1	VAHLE unipole insulated conductor, 1 m long ground	U 20/50 AC-1	127 121
	25	Rigid joints	UV 20/50	120 180
	5	Feed terminals	UE 20/50	120 220
	10	Locating clamps	USK 20 K 4	120 140
	10	End caps	UK 20	120 120
	32	Compact hangers, 5 pole	KH 20/5	126 616
	32	Bracket profiles 38/17, 230 mm long	HU 20/230	120 833
	4	Current collectors phase	KST 40	152 840
	1	Current collector ground	KST 40	152 850
	1	Collector bracket	UM 12	153 504

Standard configuration, 60 m power supply system, 3 pole + ground, 200 A

	Qty.	Description	Type	Cat.-No.
<p>Dimensions in parenthesis include insulators GH 40 with rail holder UAK 20</p>	30	VAHLE unipole insulated conductors, 6 m long phase	U 20/50 C-6	127 036
	10	VAHLE unipole insulated conductors, 6 m long ground	U 20/50 C-6	127 136
	36	Rigid joints	UV 20/50	120 180
	4	Feed terminals	UE 20/50	120 220
	8	Locating clamps	USK 20 K 4	120 140
	8	End caps	UK 20	120 120
	244	Insulated hangers	UAM 20	126 540
	3	Current collectors phase	UDST 120	120 967
	1	Current collector ground	UDST 120	120 968
	1	Collector bracket	UM 16	126 574



INSULATED CONDUCTORS U 30

Type	U 30/125 AC	U 30/225 AC	U 30/120 CE	U 30/75 C	
Weight kg/m	0.920	1.140	1.440	1.100	
Standard shrouding, color green					
Cat.-No. phase *	130 16 •	130 20 •	130 24 •	130 28 •	
Cat.-No. ground *	130 17 •	130 21 •	130 25 •	130 29 •	
High temperature shrouding, color grey					
Cat.-No. phase *	130 18 •	130 22 •	130 26 •	130 30 •	
Cat.-No. ground *	130 19 •	130 23 •	130 27 •	130 31 •	

Type	U 30/100 C	U 30/130 CH	U 30/150 C	U 30/200 C	U 30/200 CH
Weight kg/m	1.360	1.540	1.780	2.180	2.180
Standard shrouding, color green					
Cat.-No. phase *	130 32 •	130 36 •	130 40 •	130 44 •	130 48 •
Cat.-No. ground *	130 33 •	130 37 •	130 41 •	130 45 •	130 49 •
High temperature shrouding, color grey					
Cat.-No. phase *	130 34 •	130 38 •	130 42 •	130 46 •	130 50 •
Cat.-No. ground *	130 35 •	130 39 •	130 43 •	130 47 •	130 51 •

Engineering data

Conductor Type	Conductor cross section mm ²			Leakage distance of shroud mm	max. voltage V	max. continuous ampere capacity A at 35° C	Resistance (R) Ohm/1000 m	Impedance Ohm/1000 m based on 50 Hz & 80 mm cond. spacing
	Copper	Aluminum	Steel					
U 30/125 AC	18	110		90	1000	280	0.226	0.284
U 30/225 AC	18	210		90	1000	330	0.134	0.216
U 30/120 CE	100		18	100	1000	330	0.178	0.222
U 30/ 75 C	75			100	1000	280	0.238	0.280
U 30/100 C	100			105	1000	330	0.178	0.264
U 30/130 CH	130			95	1000	400	0.137	0.221
U 30/150 C	150			95	1000	440	0.126	0.219
U 30/200 C	200			90	1000	530	0.090	0.195
U 30/200 CH	200			90	1000	530	0.090	0.195

Conductor Code:

U = Insulated Conductors
 30 = Shroud Size
 75-225 = Conductor Cross Sectional Area (mm²)
 AC = Aluminum/copper conductor
 CE = Copper/stainless steel conductor
 C = Copper conductor
 CH = Copper conductor with extra deep groove for high speed applications

Application:

for indoor and outdoor

Supply length:

6 m standard
 Shorter lengths are available.

Bending:

factory fabricated R = 800-4500 mm
 field fabrication R > 4500 mm

Support spacing:

– for straight runs and lateral curves: 1500 mm
 – for horizontal curves $R_H < 10$ m: 750 mm
 – for horizontal curves $R_H > 10$ m: 1500 mm

Heating system:

The conductors Type U 30/125 AC and U 30/75 C can be equipped with heating cable for icing conditions.

See page 4 for chemical and electrical properties.

Rigid joints

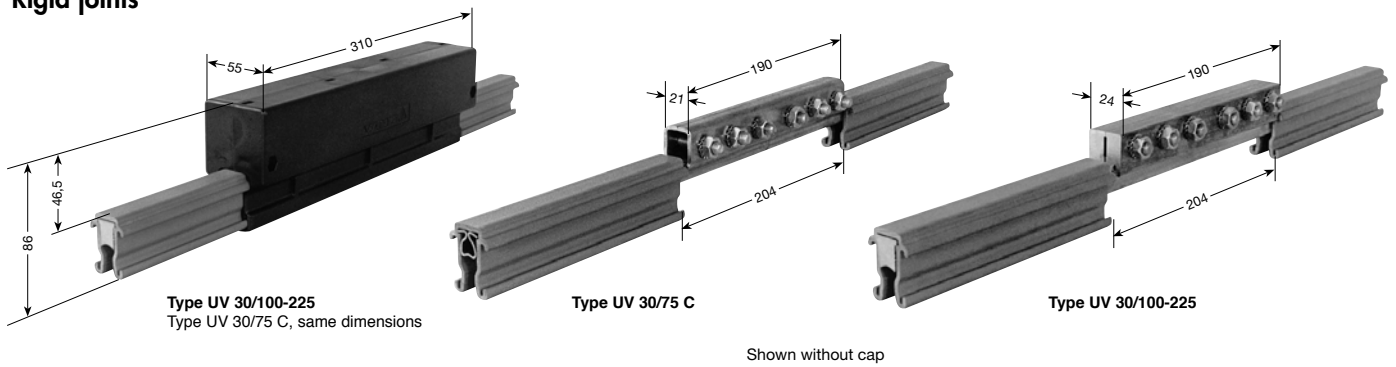

Type	for conductor type	Weight kg	Cat.-No.
UV 30/75 C	U 30/75 C	0.780	130 525
UV 30/75 C K 4*	U 30/75 C	0.780	130 526
UV 30/100-225	U 30/125 AC, U 30/225 AC, U 30/120 CE, U 30/100 C,	1.180	130 527
UV 30/100-225 K 4*	U 30/130 CH, U 30/150 C, U 30/200 C, U 30/200 CH,	1.180	130 528

Expansion sections

factory assembled to 1.5 m long conductor section, incl. one rigid joint.

The 1.5 m expansion assembly is part of the system length. Expansion section for 0-70 mm gap available.

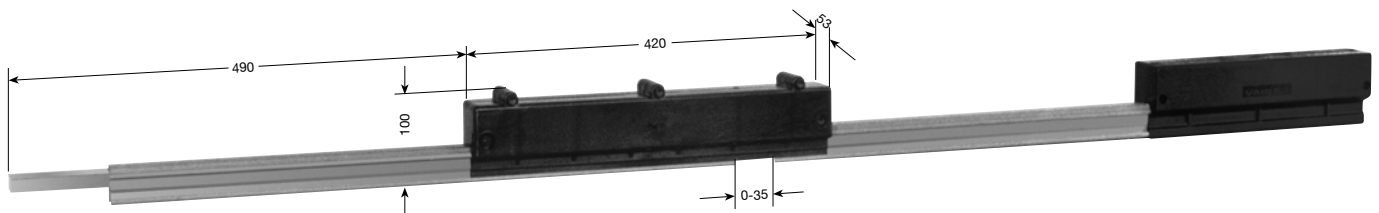

Standard shrouding, color green

Type	Weight kg	Cat.-No.	
		phase	ground
UDV 30/125 AC	4.200	130 529	130 530
UDV 30/225 AC	4.530	130 531	130 532
UDV 30/120 CE	4.980	130 533	130 534
UDV 30/ 75 C	4.470	130 535	130 536
UDV 30/100 C	4.860	130 537	130 538
UDV 30/130 CH	5.130	130 539	130 540
UDV 30/150 C	5.490	130 541	130 542
UDV 30/200 C	6.090	130 543	130 544
UDV 30/200 CH	6.090	130 545	130 546
UDV 30/125 AC K 4*	4.200	130 547	130 548
UDV 30/225 AC K 4*	4.530	130 549	130 550
UDV 30/120 CE K 4*	4.980	130 551	130 552
UDV 30/ 75 C K 4*	4.470	130 553	130 554
UDV 30/100 C K 4*	4.860	130 555	130 556
UDV 30/130 CH K 4*	5.130	130 557	130 558
UDV 30/150 C K 4*	5.490	130 559	130 560
UDV 30/200 C K 4*	6.090	130 561	130 562
UDV 30/200 CH K 4*	6.090	130 563	130 564

High temperature shrouding, color grey

Type	Weight kg	Cat.-No.	
		phase	ground
UDV 30/125 AC	4.200	130 565	130 566
UDV 30/225 AC	4.530	130 567	130 568
UDV 30/120 CE	4.980	130 569	130 570
UDV 30/ 75 C	4.470	130 571	130 572
UDV 30/100 C	4.860	130 573	130 574
UDV 30/130 CH	5.130	130 575	130 576
UDV 30/150 C	5.490	130 577	130 578
UDV 30/200 C	6.090	130 579	130 580
UDV 30/200 CH	6.090	130 581	130 582
UDV 30/125 AC K 4*	4.200	130 583	130 584
UDV 30/225 AC K 4*	4.530	130 585	130 586
UDV 30/120 CE K 4*	4.980	130 587	130 588
UDV 30/ 75 C K 4*	4.470	130 589	130 590
UDV 30/100 C K 4*	4.860	130 591	130 592
UDV 30/130 CH K 4*	5.130	130 593	130 594
UDV 30/150 C K 4*	5.490	130 595	130 596
UDV 30/200 C K 4*	6.090	130 597	130 598
UDV 30/200 CH K 4*	6.090	130 599	130 600

* Stainless steel hardware



ACCESSORIES FOR U 30

Feed terminals

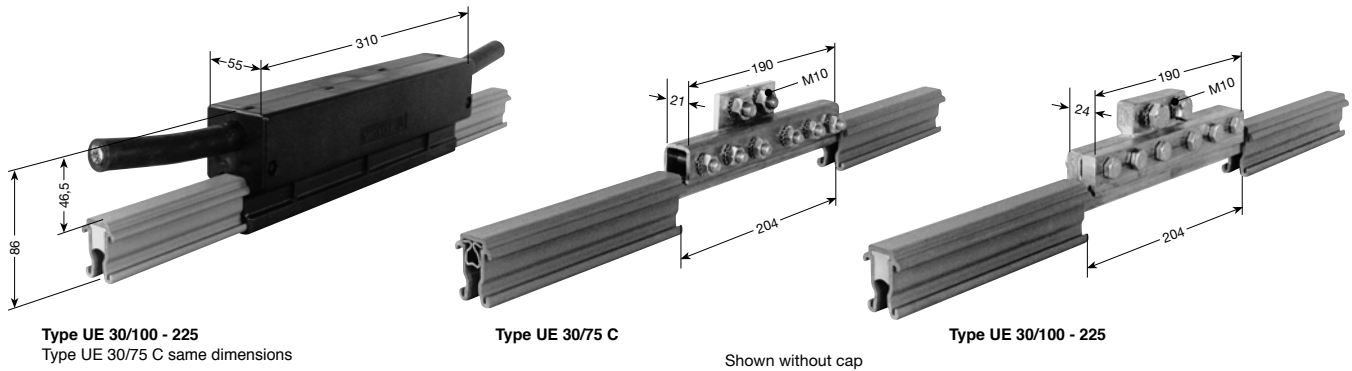

Type	Connecting cable max. mm ²	Weight kg	Cat.-No.
UE 30/75 C	2 x 70	0.990	130 601
UE 30/75 CK 4*	2 x 70	0.990	130 602
UE 30/100 -225	2 x 70	1.480	130 603
UE 30/100-225 K 4*	2 x 70	1.480	130 604

Feed terminals

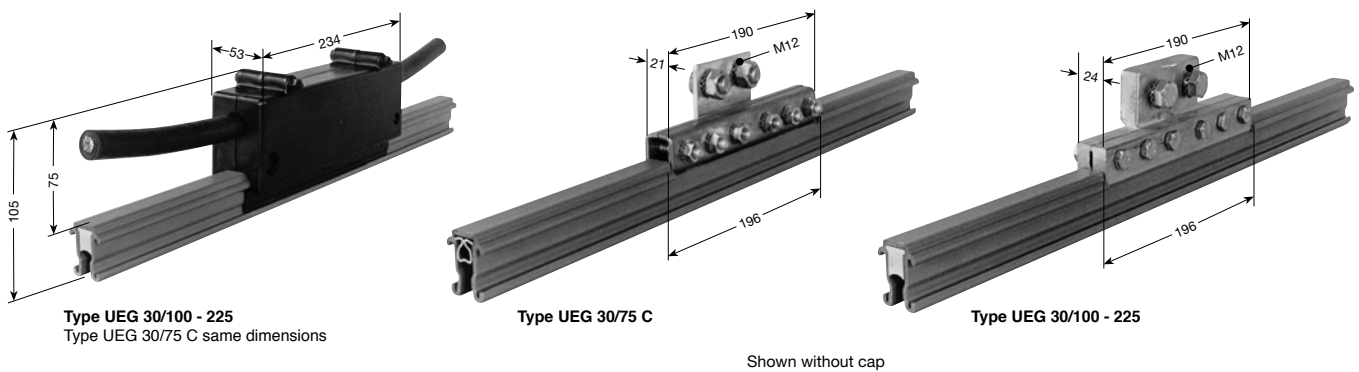

For mid-rail assembly only.

Type	Connecting cable max. mm ²	Weight kg	Cat.-No.
UEG 30/75 C	2 x 95	0.940	130 605
UEG 30/75 CK 4*	2 x 95	0.940	130 606
UEG 30/100-225	2 x 120	1.615	130 607
UEG 30/100-225 K 4*	2 x 120	1.615	130 608

Contact paste for joints and feeds

20 g for ca. 40 joints	Cat.-No. 132 240
500 g for ca. 1000 joints	Cat.-No. 132 250

Locating clamp

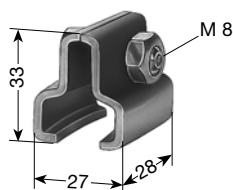

Type	Weight kg	Cat.-No.
USK 30 K 4*	0.065	133 537

End caps

L = loose, incl. locking hardware
 M = factory assembled



Type	Weight kg	Cat.-No.
UK 30-L	0.025	132 120
UK 30-M	0.025	130 158

Transfer guides

Transfer guides are used for transfer or power interrupting applications.
Max. vertical and horizontal offset: ± 4 mm, max. air gap: 10 mm.

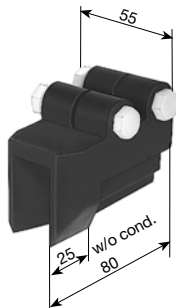

Type	Weight kg	Cat.-No.
US 30/125 AC	0.090	133 624
US 30/225 AC	0.090	133 538
US 30/120 CE	0.090	133 587
US 30/ 75 C	0.090	133 250
US 30/100 C	0.090	133 260
US 30/130 CH	0.090	133 280
US 30/150 C	0.090	133 290
US 30/200 C	0.090	133 300
US 30/200 CH	0.090	133 791

Transfer guides US 30 are fastened to conductor ends by means of two screws.

Isolating sections

Type M: Factory assembled per system layout

Type L: Loose, including two locking pins 4 x 18

Position of isolating sections per system layout. Use one extra hanger each side, max. 300 mm away for stability.

Rails, hangers & feed terminal to be ordered separately.

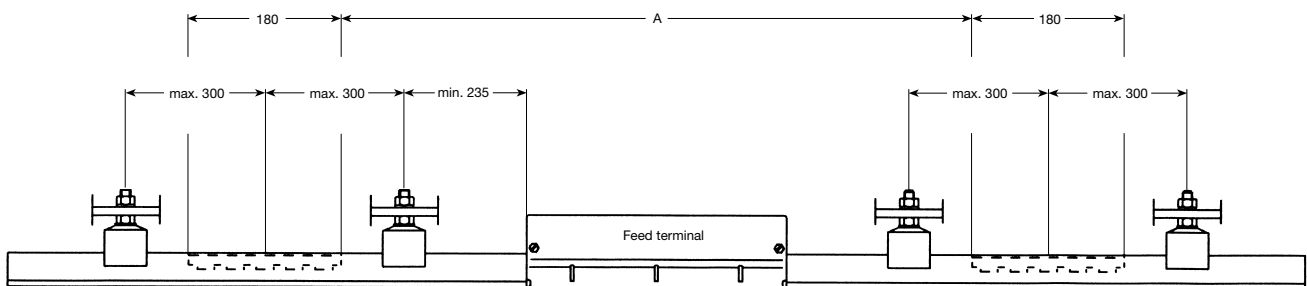
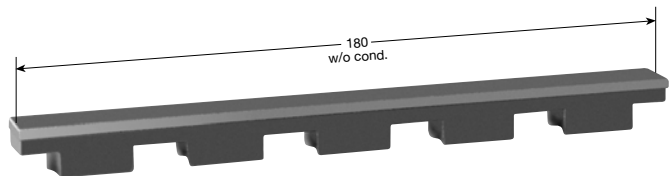

To avoid voltage by-pass by carbon brushes and to separate maintenance bays, control and main feed sections, double isolating sections are recommended.

Dim. **A** depends on type and number of current collectors and stopping distance of the crane.

Type	Weight kg	Cat.-No.
IT/U 30/125 AC-M	0.021	133 625
IT/U 30/225 AC-M	0.021	133 626
IT/U 30/120 CE-M	0.021	133 588
IT/U 30/ 75 C -M	0.021	133 070
IT/U 30/100 C -M	0.021	133 080
IT/U 30/130 CH-M	0.021	133 100
IT/U 30/150 C -M	0.021	133 110
IT/U 30/200 C -M	0.021	133 120
IT/U 30/200 CH-M	0.021	133 792

Type	Weight kg	Cat.-No.
IT/U 30/125 AC-L	0.021	132 590
IT/U 30/225 AC-L	0.021	132 630
IT/U 30/120 CE-L	0.021	132 580
IT/U 30/ 75 C -L	0.021	132 560
IT/U 30/100 C -L	0.021	132 570
IT/U 30/130 CH-L	0.021	132 600
IT/U 30/150 C -L	0.021	132 610
IT/U 30/200 C -L	0.021	132 620
IT/U 30/200 CH-L	0.021	132 640



ACCESSORIES FOR U 30

Insulated hangers

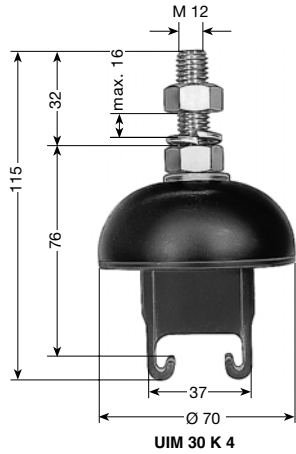

UIM 30 K 4

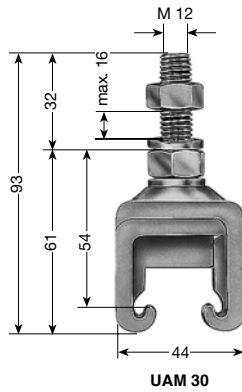

UAM 30

Type	Weight kg	Cat.-No.
UIM 30 K 4*	0.160	133 768
UAM 30	0.160	132 690
UAM 30 K 4*	0.160	132 700

Hangers

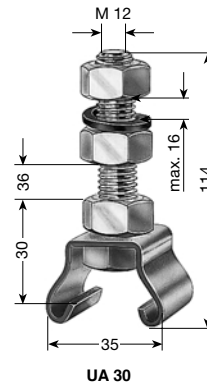

UA 30

Type	Weight kg	Cat.-No.
UA 30	0.165	132 150
UA 30 K 4*	0.165	132 510

Insulators for max. 1000 V

High voltage insulators are available

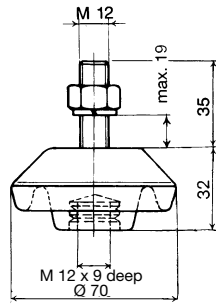

Type	Weight kg	Cat.-No.
GHH 30 – M 12	0.245	130 000
GHH 30 – M 12 K 4*	0.245	130 002

Cantilever strength = 4500 N
Leakage distance = 70 mm

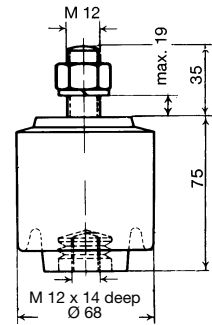

Type	Weight kg	Cat.-No.
GHH 75 – M 12	0.560	133 564
GHH 75 – M 12 K 4*	0.560	133 566

Cantilever strength = 6500 N
Leakage distance = 115 mm

Rail holders

to go with insulators

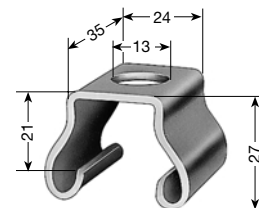
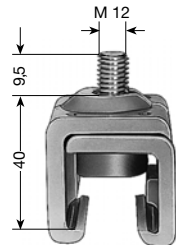

Supplied with bolt M 12 x 12

Type	Weight kg	Cat.-No.
UAK 30 K 4*	0.100	133 568

Type	Weight kg	Cat.-No.
UAS 30 K 4*	0.080	132 710



Any number of conductors can be assembled by cutting/combining the compact hangers.

Joints and feed terminals must be mounted staggered by 300 mm.

Use collectors of series KST only.

Compact hanger, 4 pole for direct bolting to supporting structure

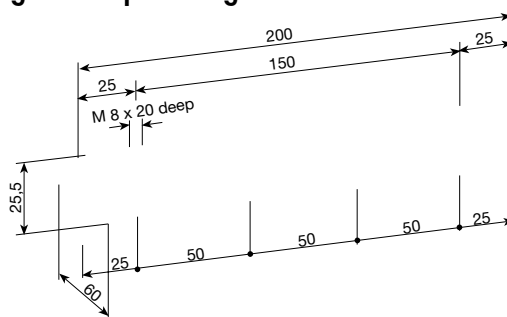

Type	Weight kg	Cat.-No.
KA 30/4	0.172	133 570

Compact hanger, 4 pole to go with bracket 38/17

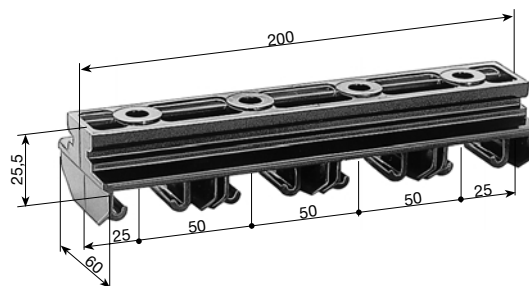

Type	Weight kg	Cat.-No.
KH 30/4	0.165	133 571

Attachment hardware for KA hangers

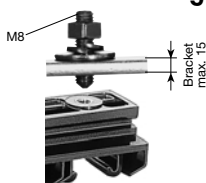

Type	Weight kg	Cat.-No.
Hardware BE 8	0.028	130 060
Hardware BE 8 K 4*	0.028	130 111

Flat washers

(required on both sides of brackets with slotted holes)

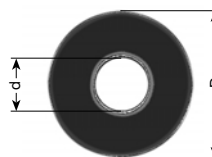

Type	Threat	d mm	D mm	S mm	Weight kg	Cat.-No.
Washer 8.4	M 8	8.4	25	2	0.007	130112
Washer 8.4 K 4*	M 8	8.4	25	2	0.007	130110

Bracket profiles 38/17

incl. locking hardware

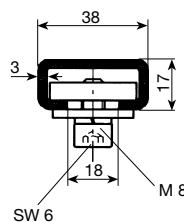

Type	Length mm	Number of poles	Weight kg	Cat.-No.
HU 30/400	400	5	0.820	130113
HU 30/600	600	10	1.160	130 114

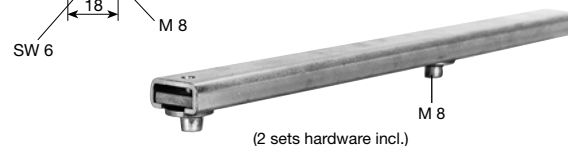

Transfer funnel for compact arrangement EMK 30/1-6.

Use collectors type KSTU 140 and KDSTU 280 only.

Transfer funnels will be required in conjunction with spur lines, switches and turntables.

Consult factory for details, indicating type of rail, number of conductors, position of ground etc. within your system.

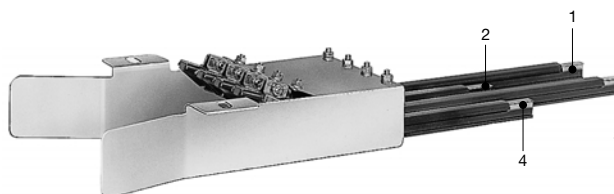

* Stainless steel hardware



CURRENT COLLECTORS FOR U 30

Current collector

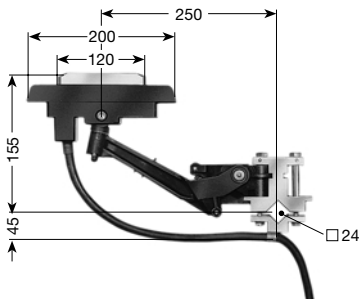

with 2 m connecting cable
 lift + 45 / - 40 mm
 swivel ± 60 mm
 contact pressure: ~ 30 N

Double collector

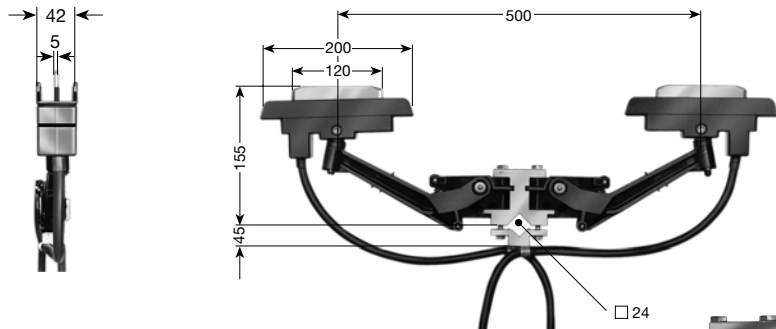

with 2 x 2 m connecting cable
 lift + 45 / - 40 mm
 swivel ± 60 mm
 contact pressure: ~ 30 N per brush

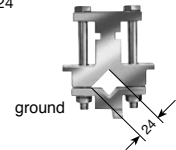

Type	Am- pacity A*	Connecting cable		Weight kg	Cat.-No.		Type	Am- pacity A*	Connecting cable		Weight kg	Cat.-No.	
		mm ²	ø max. mm		phase black	ground yellow			mm ²	ø max. mm		phase black	ground yellow
KST 100/30	100	16	14.5	1.550	133 938	133 939	KDST 200/30	200	16	14.5	3.100	133 940	133 941

Current collectors for transfer applications KSTU 140/30

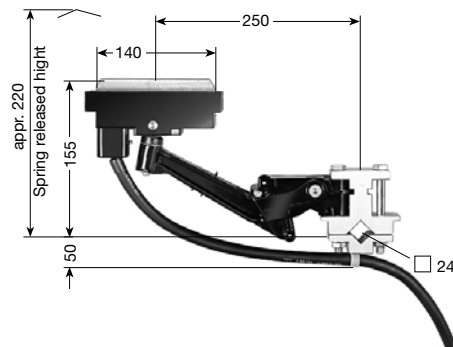

with 2 m connecting cable
 lift +45 / - 40 mm
 swivel ± 60 mm
 contact pressure: ~ 29 N

Double collectors for transfer applications KDSTU 280/30

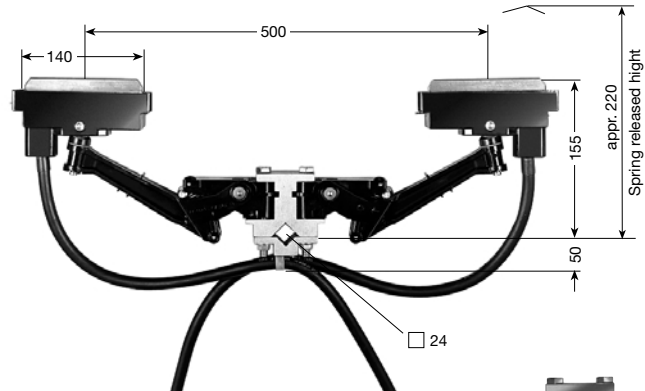

with 2 x 2 m connecting cable
 lift + 45 / - 40 mm
 swivel ± 60 mm
 contact pressure: ~ 29 N per brush

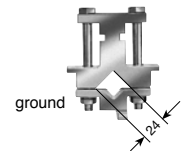

Type	Am- pacity A**	Connecting cable		Weight kg	Cat.-No.		Type	Am- pacity A**	Connecting cable		Weight kg	Cat.-No.	
		mm ²	ø max. mm		phase black	ground yellow			mm ²	ø max. mm		phase black	ground yellow
KST 140/30*	140	25	16.5	1.935	130 048	130 049	KDST 280/30*	280	25	16.5	3.395	130 052	130 053
KSTU 140/30*	140	25	16.5	1.990	130 050	130 051	KDSTU 280/30*	280	25	16.5	3.535	130 054	130 055

Collector bracket

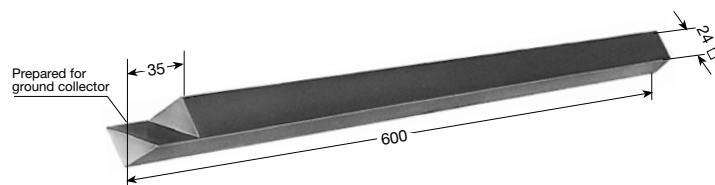

Type	Weight kg	Cat.-No.
UM 24	2.600	175 076

Longer brackets furnished on special order. In this case an extra support is to be provided to avoid bending or twisting of the collector bracket.

* Specials for acid laden environments on request.
 ** Reduced ampacity when using rail type U 30/120 CE – consult factory.

COLLECTOR COMPONENTS U 30 · EXAMPLE FOR ORDERING



Copper-graphite brush

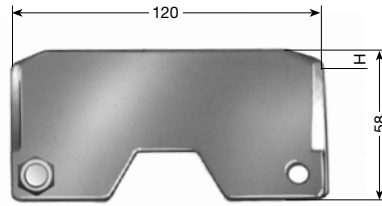

KMK 100/30

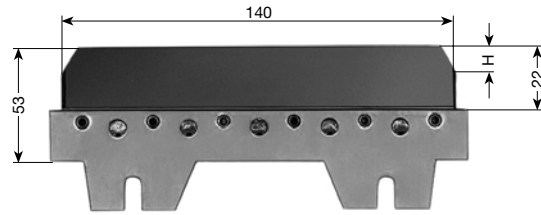

KMK 140/30

Dim. H: max. wear for U 30/100 C

Type	for collector	max. wear H mm	Weight kg	Cat.-No.
KMK 100/30	KST 100/30, KDST 200/30	4	0.198	130 609
KMK 140/30	KST 140/30, KDST 280/30, KSTU 140/30, KDSTU 280/30	5,5	0.177	133 590

Tension spring

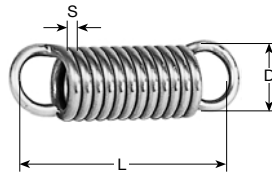

Type	for collector	Weight kg	L mm	D mm	S mm	Cat.-No.
ZF 6	KST 100/30, KST 140/30, KDST 200/30 KST 140/30, KDST 280/30, KSTU 140/30, KDSTU 280/30	0.020	56.50	17.30	2.25	133 592

Example for ordering 160 m power supply system, 3 pole + ground, 530 A

	Qty.	Description	Type	Cat.-No.	
	78	VAHLE unipole insulated conductors, 6 m long	phase	U 30/200 C-6	130 446
	3	VAHLE unipole insulated conductors, 1 m long	phase	U 30/200 C-1	130 441
	26	VAHLE unipole insulated conductors, 6 m long	ground	U 30/100 C-6*	130 336
	1	VAHLE unipole insulated conductor, 1 m long	ground	U 30/100 C-1*	130 331
	6	Expansion sections each 1.5 m long	phase	UDV 30/200 C	130 561
	2	idem	ground	UDV 30/100 C*	130 538
	104	Rigid joints		UV 30/100-225	130 527
	8	Feed terminals		UE 30/100-225	130 603
	24	Locating clamps		USK 30 K 4	133 537
	8	End caps		UK 30	132 120
	432	Insulated hangers		UAM 30	132 690
	6	Double collectors	phase	KDST 280/30	130 052
	1	Current collector	ground	KDST 280/30*	130 053
	2	Collector brackets		UM 24	132 460

Dimensions in parenthesis include insulators GHH 75/UAS 30 with railholder UAK 30 K 4

* Capacity reduces per VDE 0100, part 540



COLLECTOR COMPONENTS U 30

for KST 100/30 thru KDST 200/30

Part.-No.	Description	Weight kg	Cat.-No.
1	Brush (see page 31)	–	–
2	Brush holder for KST 100	0.195	170 338
3	Collector base for KST 100	0.662	170 340
4	Collector base for KST 100	0.731	170 341
5	Collector base for KDST 200	0.887	170 342
6	Collector base for KDST 200	0.953	170 343
7	Connecting cable RKA 16/8 PH, 2 m long	0.614	170 344
8	Terminal bolt M 8 x 20 K 4	0.459	170 345
9	Tension spring (see page 31)	0.022	170 818
		–	–

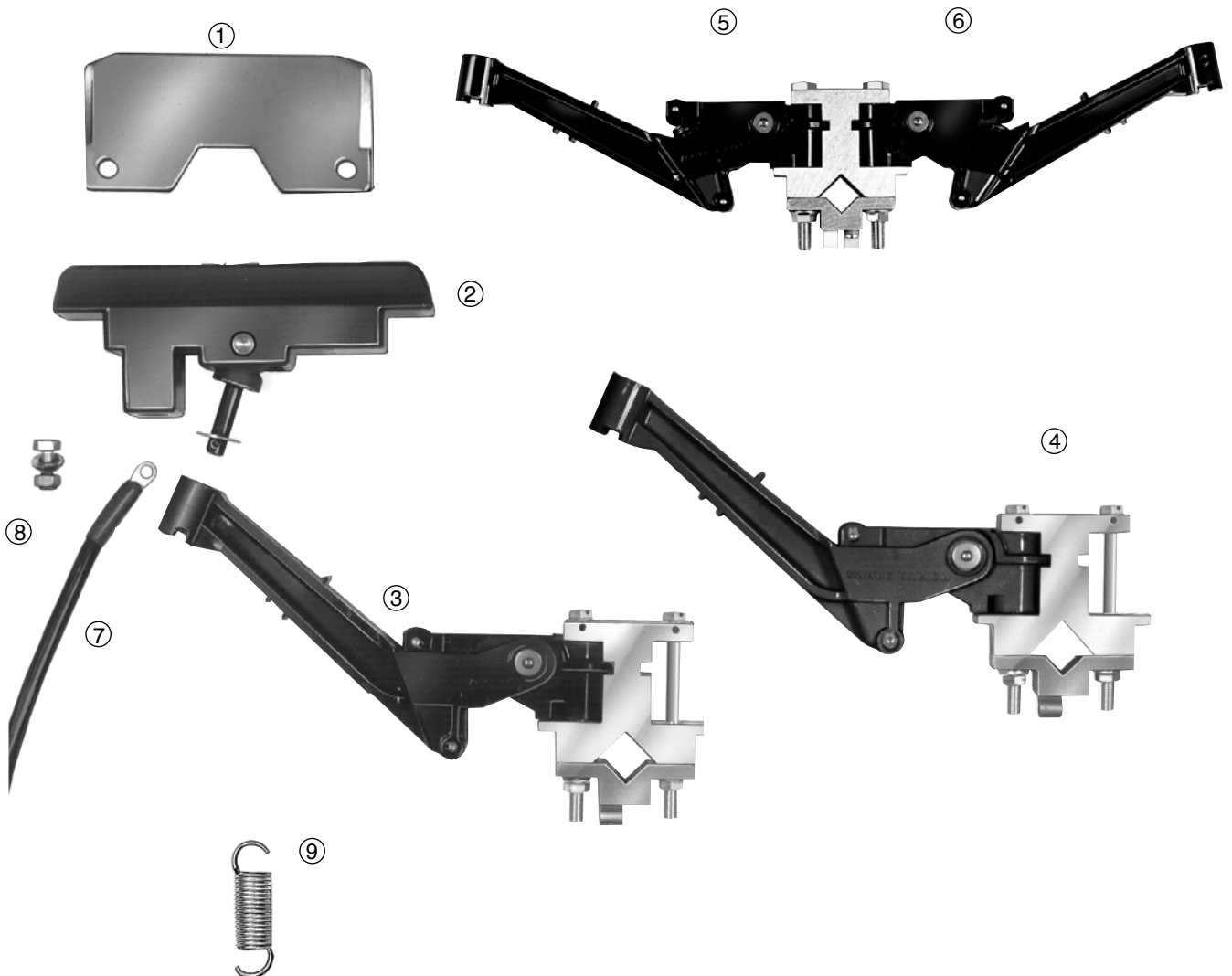

for KST 140/30 thru KDSTU 280/30

Part.-No.	Description		Weight kg	Cat.-No.
1	Brush (see page 31)		–	–
2	Brush holder for KST 140	phase ground	0.375	170 169
		ground		170 169
3	Collector base for KST 140	phase ground	0.662	170 795
4		ground	0.731	170 796
3	Collector base for KSTU 140	phase ground	0.555	170 555
4		ground		170 556
5	Collector base for KDST 280	phase ground	0.887	170 791
6		ground	0.953	170 792
5	Collector base for KDSTU 280	phase ground	0.795	170 557
6		ground		170 558
7	Connecting cable RKA 25/8 PH, 2 m long	phase ground	0.840	170 173
	Connecting cable RKA 25/8 PE, 2 m long	ground	0.600	170 174
8	Terminal bolt M 8 x 12 K 4		0.010	170 871
9	Rubber spring, complete for KSTU 140, KDSTU 280		0.035	170 412
10	Tension spring (see page 31)		–	–

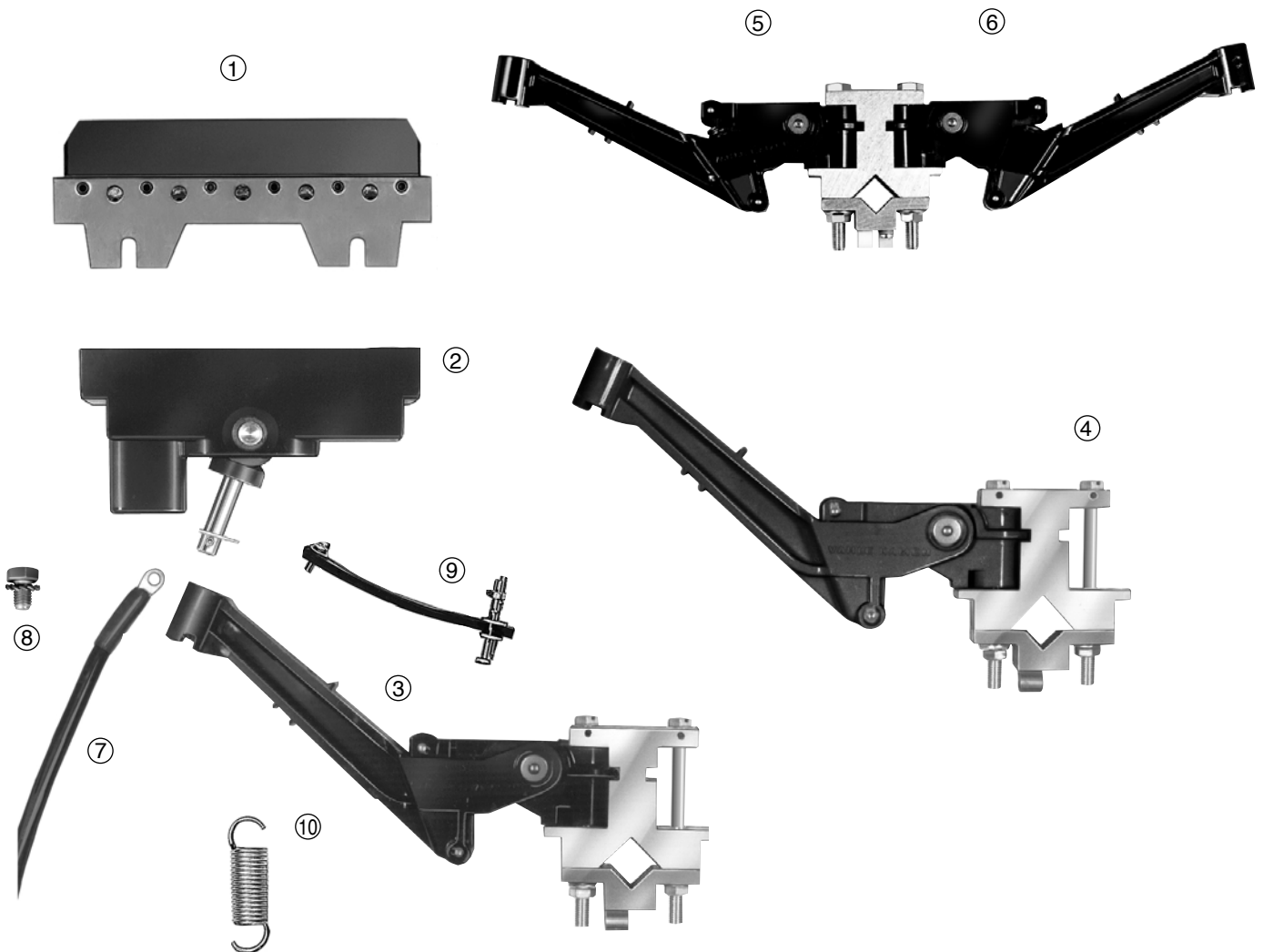



INSULATED CONDUCTORS U 40

Type	U 40/300 AC	U 40/200 C
Weight kg/m	2.000	2.550
Standard shrouding, color green		
Cat.-No. * phase	136 03 •	136 01 •
Cat.-No. * ground	136 18 •	136 15 •
High temperature shrouding, color grey		
Cat.-No. * phase	136 09 •	136 06 •
Cat.-No. * ground	136 27 •	136 24 •

Type	U 40/400 C	U 40/400 CH
Weight kg/m	4.380	4.360
Standard shrouding, color green		
Cat.-No. * phase	134 35 •	136 04 •
Cat.-No. * ground	136 19 •	136 20 •
High temperature shrouding, color grey		
Cat.-No. * phase	136 10 •	136 11 •
Cat.-No. * ground	136 28 •	136 29 •

Conductor code:

U = Unipole insulated conductor
 40 = Shroud size
 200-500 = Conductor cross sectional area (mm²)
 AC = Aluminium/Copper conductor
 C = Copper conductor
 CH = Copper conductor with extra deep groove for high speed applications
 CHH = See CH plus for heating

Application:

indoors and outdoors

Supply lengths:

6 m standard
 shorter lengths are available.

Support spacing:

2 m

Heating system:

The conductors type U 40/300 AC, U 40/200 C, U 40/300 CH and U 40/500 CHH can be equipped with heating cable for icing conditions.

Factory-fabricated radius bends to your drawings or sketches are available.

See page 4 for electrical and mechanical properties.

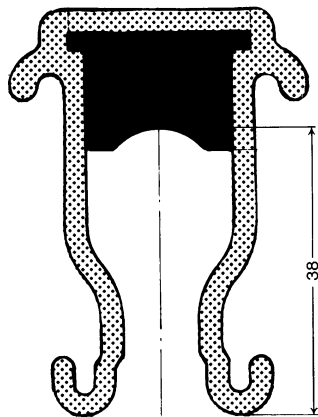
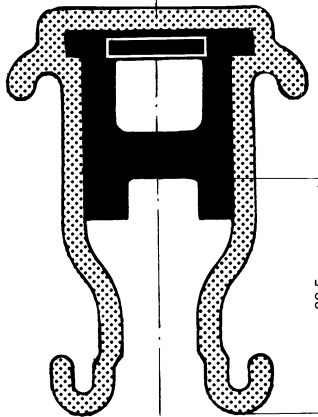
		
	U 40/300 C	U 40/300 CH
	3.460	3.500
	134 34 • 136 16 •	136 02 • 136 17 •
	136 07 • 136 25 •	136 08 • 136 26 •

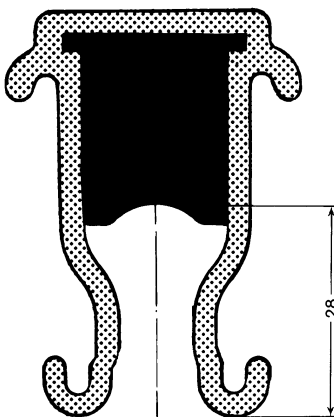
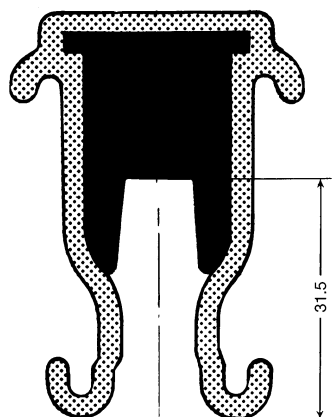
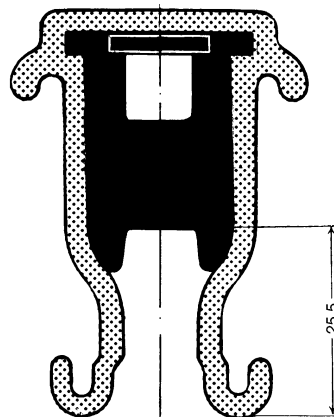
		
U 40/500 C	U 40/500 CH	U 40/500 CHH
5.240	5.250	5.000
134 36 • 136 21 •	134 15 • 136 22 •	136 05 • 136 23 •
136 12 • 136 30 •	136 13 • 136 31 •	136 14 • 136 32 •

Engineering data

Conductor Type	Conductor cross section mm ²		Leakage distance of shroud mm	Max. voltage V	max. continuous ampere capacity A at 35 °C	Resistance (R) Ohm/1000 m	Impedance Ohm/1000 m based on 50 Hz & 130 mm cond. spacing
	copper	aluminium					
U 40/300 AC	50	250	130	1000	490	0.096	0.198
U 40/200 C	200		130	1000	600	0.089	0.170
U 40/300 C	300		135	1000	700	0.063	0.178
U 40/300 CH	300		130	1000	700	0.063	0.178
U 40/400 C	400		130	1000	860	0.047	0.168
U 40/400 CH	400		130	1000	860	0.047	0.168
U 40/500 C	500		125	1000	1000	0.038	0.161
U 40/500 CH	500		120	1000	1000	0.038	0.161
U 40/500 CHH	500		120	1000	1000	0.038	0.161



ACCESSORIES FOR U 40

Rigid joints

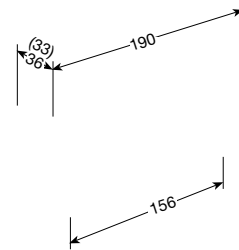
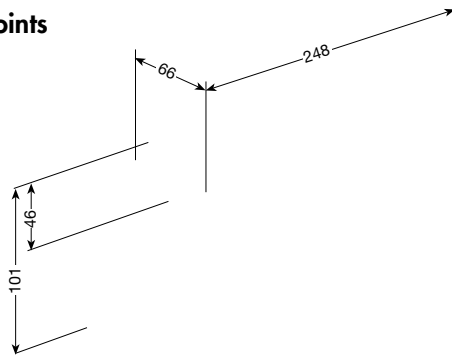

shown without cap
dimension in parenthesis for UV 40/200

Type	Weight kg	Cat.-No.
UV 40/200	1.645	134 180
UV 40/200 K 4*	1.645	135 140

Type	Weight kg	Cat.-No.
UV 40/300-500	1.660	135 384
UV 40/300-500 K 4*	1.660	135 385

Expansion sections

Factory-assembled to 2 m long conductor section, including one rigid joint.
The 2 m expansion assembly is part of the system length.

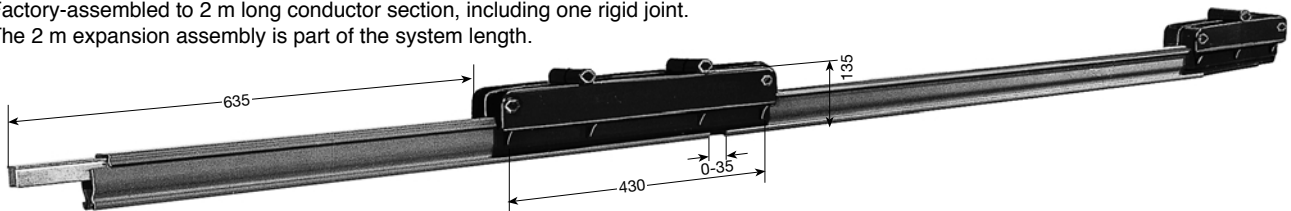

Standard shrouding, color green

Type	Weight kg	Cat.-No.	
		phase	ground
UDV 40/300 AC	8.250	135 211	135 212
UDV 40/200 C	9.350	135 142	135 143
UDV 40/300 C	11.170	134 690	134 700
UDV 40/300 CH	11.250	135 144	135 145
UDV 40/400 C	13.010	134 710	134 720
UDV 40/400 CH	12.970	135 146	135 147
UDV 40/500 C	14.730	134 730	134 740
UDV 40/500 CH	14.750	134 750	134 760
UDV 40/500 CHH	14.250	135 390	135 391
UDV 40/300 AC K 4*	8.250	135 152	135 153
UDV 40/200 C K 4*	9.350	135 154	135 155
UDV 40/300 C K 4*	11.170	135 156	135 157
UDV 40/300 CH K 4*	11.250	135 148	135 149
UDV 40/400 C K 4 *	13.010	135 158	135 159
UDV 40/400 CH K 4*	12.970	135 150	135 151
UDV 40/500 C K 4*	14.730	135 160	135 161
UDV 40/500 CH K 4*	14.750	135 162	135 163
UDV 40/500 CHH K 4*	14.250	135 392	135 393

High temperature shrouding, color grey

Type	Weight kg	Cat.-No.	
		phase	ground
UDV 40/300 AC	8.250	135 278	135 279
UDV 40/200 C	9.350	135 272	135 273
UDV 40/300 C	11.170	135 274	135 275
UDV 40/300 CH	11.250	135 276	135 277
UDV 40/400 C	13.010	135 280	135 281
UDV 40/400 CH	12.970	135 282	135 283
UDV 40/500 C	14.730	135 284	135 285
UDV 40/500 CH	14.750	135 286	135 287
UDV 40/500 CHH	14.250	135 370	135 371
UDV 40/300 AC K 4*	8.250	135 294	135 295
UDV 40/200 C K 4*	9.350	135 288	135 289
UDV 40/300 C K 4*	11.170	135 290	135 291
UDV 40/300 CH K 4*	11.250	135 292	135 293
UDV 40/400 C K 4 *	13.010	135 296	135 297
UDV 40/400 CH K 4*	12.970	135 298	135 299
UDV 40/500 C K 4*	14.730	135 300	135 301
UDV 40/500 CH K 4*	14.750	135 302	135 303
UDV 40/500 CHH K 4*	14.250	135 372	135 373

Contact Paste for joints and feeds

20 Grams for ca. 40 joints	Cat.-No. 120 016
500 Grams for ca. 1000 joints	Cat.-No. 120 017

Locating clamp

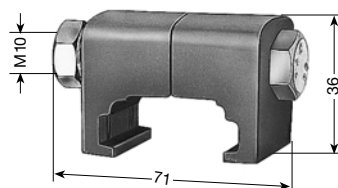

Type	Weight kg	Cat.-No.
USK 40 K 4*	0.360	134 080

End cap

L = loose, incl. locking hardware
M = factory assembled



Type	Weight kg	Cat.-No.
UK 40-L	0.040	134 060
UK 40-M	0.040	135 974



Feed terminals

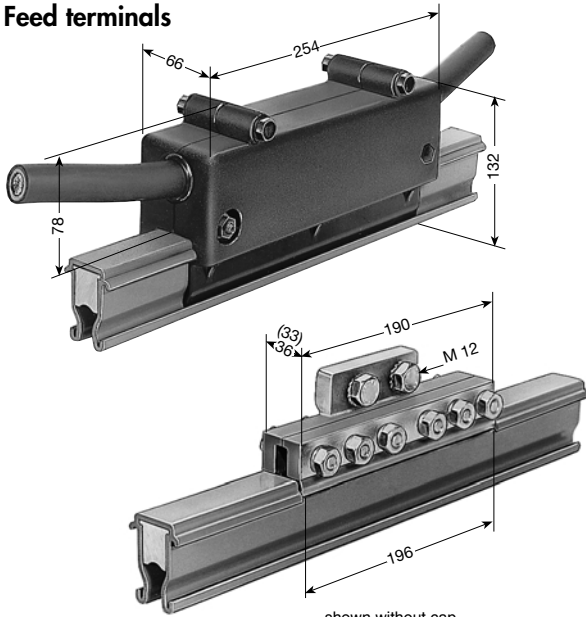

for mid-rail assembling

shown without cap
dimension in parenthesis for UE 40/200

Type	Weight kg	Cat.-No.
UE 40/200	2.120	134 280
UE 40/200 K 4*	2.120	135 164
UE 40/300-500	2.130	135 386
UE 40/300-500 K 4*	2.130	135 387

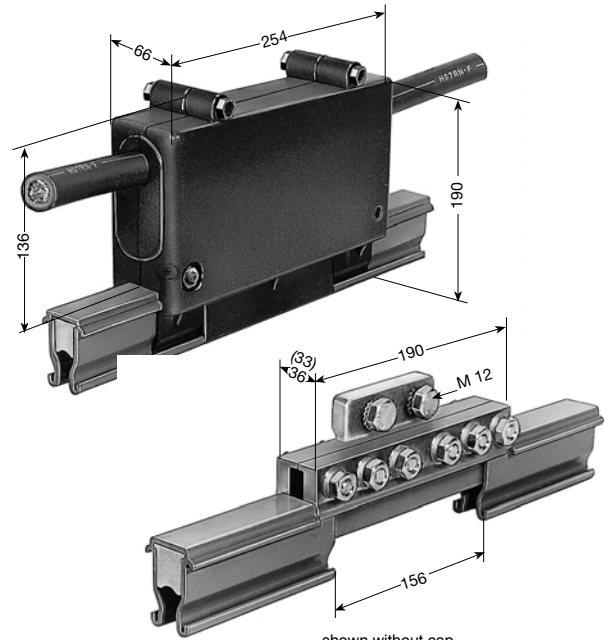

for joint mounting

shown without cap
dimension in parenthesis for UEV 40/200

Type	Weight kg	Cat.-No.
UEV 40/200	2.190	135 166
UEV 40/200 K 4*	2.190	135 168
UEV 40/300-500	2.200	135 388
UEV 40/300-500 K 4*	2.200	135 389

Feed cables: 2 of max. 95 mm²

Feed terminals

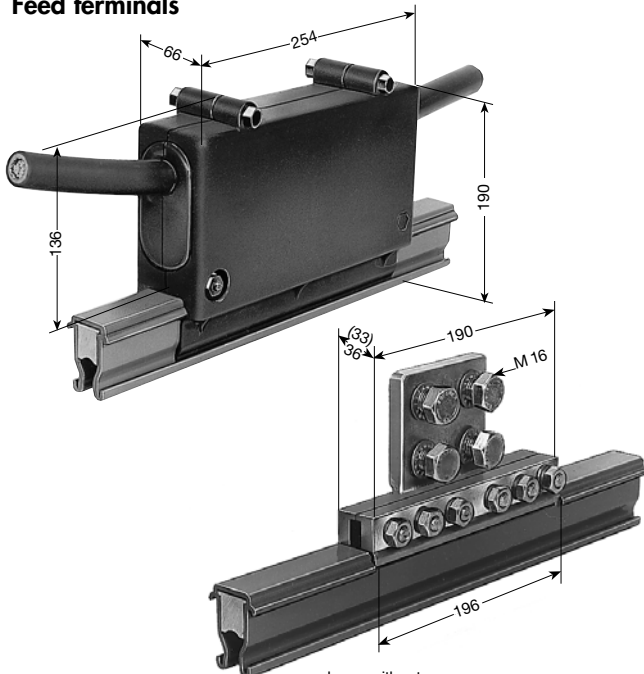

for mid-rail assembling

shown without cap
dimension in parenthesis for UEG 40/200

Type	Weight kg	Cat.-No.
UEG 40/200	2.775	135 213
UEG 40/200 K 4*	2.775	135 170
UEG 40/300-500	2.785	135 374
UEG 40/300-500 K 4*	2.785	135 375

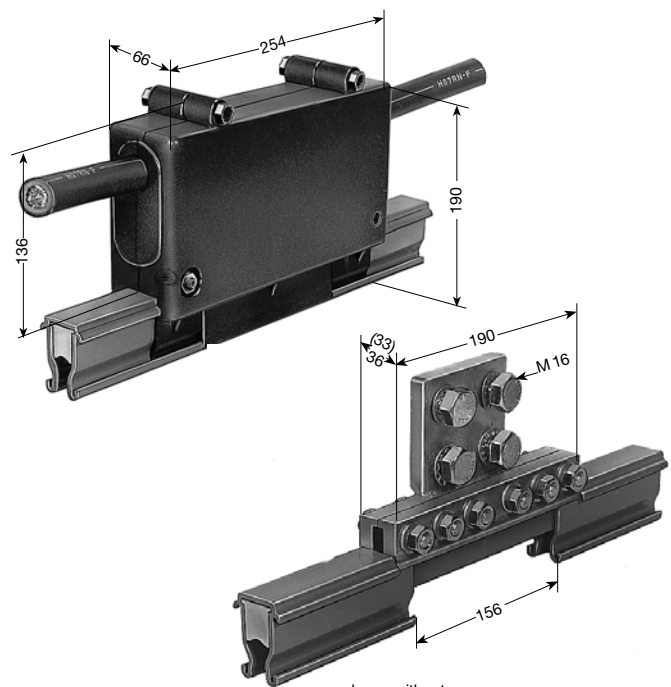

for joint mounting

shown without cap
dimension in parenthesis for UEVG 40/200

Type	Weight kg	Cat.-No.
UEVG 40/200	2.825	135 172
UEVG 40/200 K 4*	2.825	135 174
UEVG 40/300-500	2.835	135 376
UEVG 40/300-500 K 4*	2.835	135 377

Feed cables: 4 of max. 150 mm²

* Stainless steel hardware



ACCESSORIES FOR U 40

Transfer guide

Transfer guides are used for transfer or power-interrupting applications.
 Max. vertical and horizontal offset: ± 6 mm, max. air gap: 12 mm

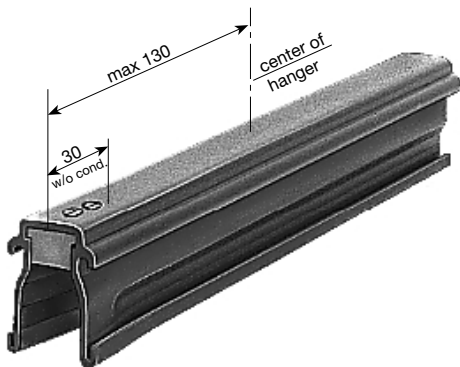

Type	Weight kg	Cat.-No.
UTI	0.014	134 910

UTI 40 are transfer buttons (bellmouth shaped conductor ends) with integrated isolating piece. They are factory assembled to layout plans.
 For separate ordering indicate conductor length and size.

Isolating sections

Type M: Factory assembled per system layout

Type L: Loose, including two locking pins 4 x 8

Position of isolating sections per system layout. Use one extra hanger each side, max. 400 mm away for stability.

Rails & hangers to be ordered separately.

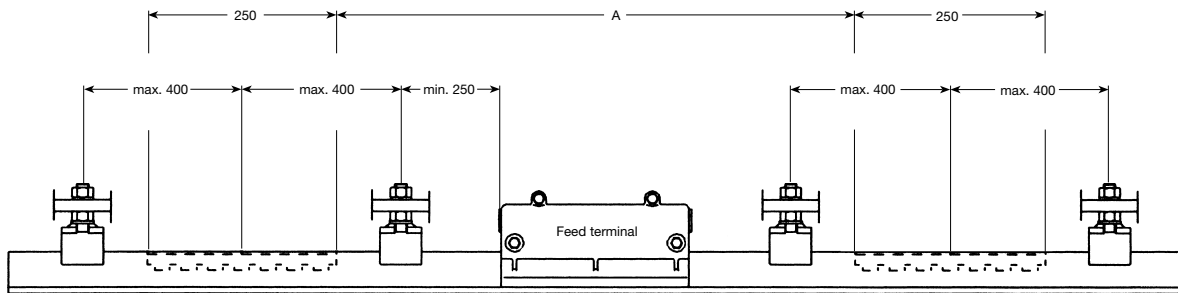
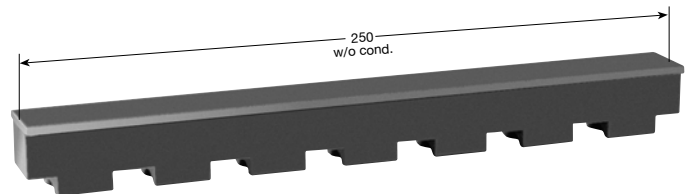

To avoid voltage by-pass by carbon brushes and to separate maintenance bays, control and main feed sections, double isolating sections are recommended.

Dim. **A** depends on type and number of current collectors and stopping distance of the crane.

Type	Weight kg	Cat.-No.
IT/U 40/300 AC -M	0.104	135 215
IT/U 40/200 C -M	0.104	135 176
IT/U 40/300 C -M	0.104	134 790
IT/U 40/300 CH -M	0.104	135 187
IT/U 40/400 C -M	0.104	134 800
IT/U 40/400 CH -M	0.104	135 188
IT/U 40/500 C -M	0.104	134 810
IT/U 40/500 CH -M	0.104	134 820
IT/U 40/500 CHH-M	0.104	135 378

Type	Weight kg	Cat.-No.
IT/U 40/300 AC -L	0.104	134 240
IT/U 40/200 C -L	0.104	134 210
IT/U 40/300 C -L	0.104	134 220
IT/U 40/300 CH -L	0.104	134 230
IT/U 40/400 C -L	0.104	134 250
IT/U 40/400 CH -L	0.104	134 260
IT/U 40/500 C -L	0.104	134 270
IT/U 40/500 CH -L	0.104	134 370
IT/U 40/500 CHH-L	0.104	134 380



Insulated hangers

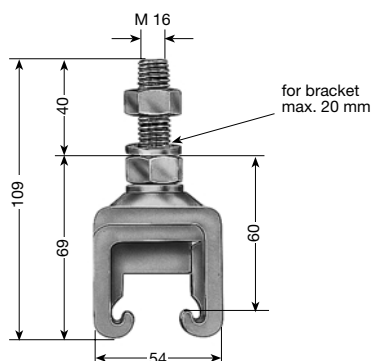

Type	Weight kg	Cat.-No.
UAM 40	0.285	135 040
UAM 40 K 4*	0.285	134 610

Hangers

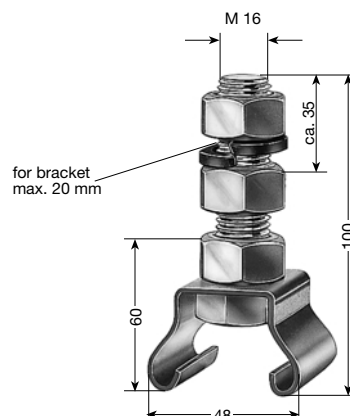

Type	Weight kg	Cat.-No.
UA 40	0.300	134 090
UA 40 K 4*	0.300	134 400

Insulators

High voltage insulators are available

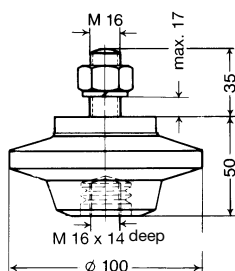

Type	Weight kg	Cat.-No.
GH 50-M 16	0.510	135 179
GH 50-M 16 K 4*	0.510	135 380

Cantilever = 9000 N
Leakage distance = 80 mm

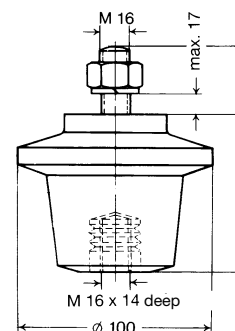

Type	Weight kg	Cat.-No.
GH 80-M 16	0.780	135 181
GH 80-M 16 K 4*	0.780	135 382

Cantilever = 9500 N
Leakage distance = 120 mm

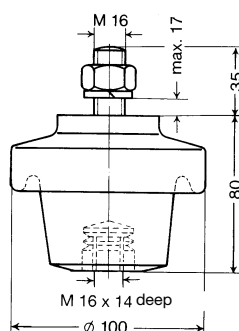

Cantilever = 9500 N
Leakage distance = 125 mm

Type	Weight kg	Cat.-No.
GHH 80-M 16	0.870	135 875
GHH 80-M 16 K 4*	0.870	135 877

Rail holders

to go with insulators

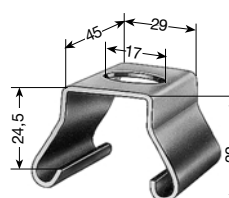

UAS
Supplied with bolt M 16 x 16
and spring washer

Type	Weight kg	Cat.-No.
UAS 40	0.140	134 100
UAS 40 K 4*	0.140	134 550
UAK 40	0.170	135 183
UAK 40 K 4*	0.170	135 185

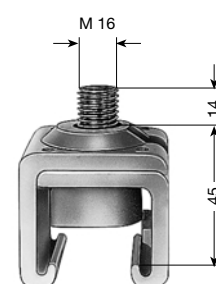

UAK
Supplied with washer

* Stainless steel hardware



COLLECTORS FOR U 40

Current collector

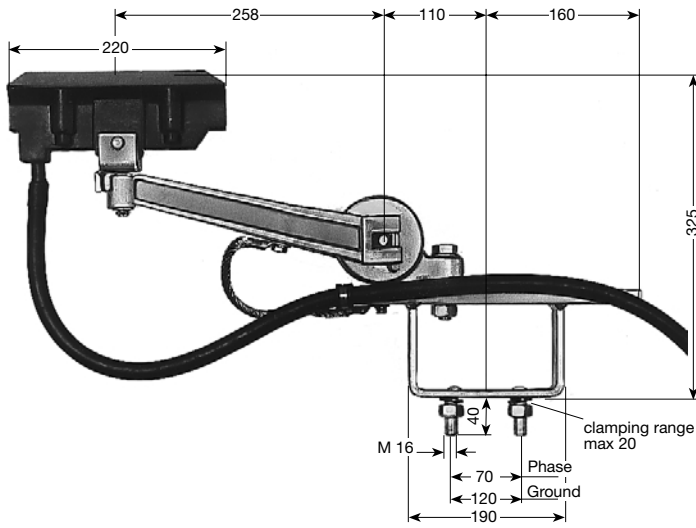

Type UST

With 2 m connecting cable
 lift ± 70 mm
 swivel ± 80 mm
 contact pressure: $\sim 50 - 70$ N

Type	Am- capacity A	Connecting cable		Weight kg	Cat.-No.	
		mm ²	o max. mm		phase black	ground yellow
UST 200	200	50	21	9,400	134 300	134 310
USTR 200	200	50	21	9,500	134 157	134 158

Longer connecting cables are available.

Double collector

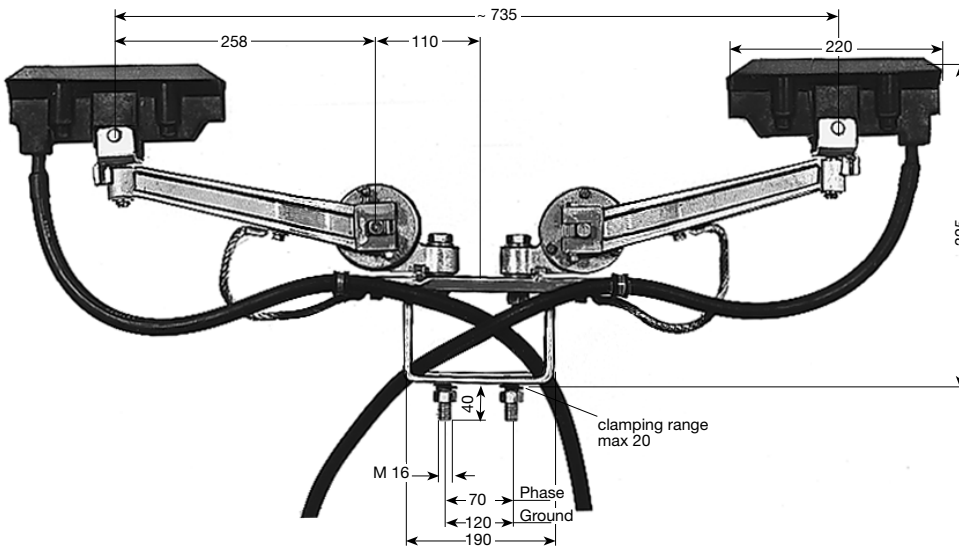

Type UDST

With 2 x 2 m connecting cable
 lift ± 70 mm
 swivel ± 80 mm
 contact pressure: $\sim 50 - 70$ N per brush

Type	Am- capacity A	Connecting cable		Weight kg	Cat.-No.	
		mm ²	o max. mm		phase black	ground yellow
UDST 400	400	50	21	15,300	134 320	134 330
UDSTR 400	400	50	21	15,500	135 912	135 980

Longer connecting cables are available.

for UST 200 & UDST 400

Part.-No.	Description	Weight kg	Cat.-No.
1	Brush KMU 200	0.410	135 207
2	Brush holder	0.730	135 206
3	Fork link with bolt	0.350	135 205
4	Lever complete	0.750	135 204
5	Spring housing, complete	2.250	135 203
6	Collector base, complete for UST 200	3.470	135 199
7	phase ground		135 200
6	Collector base, complete for UDST 400	3.490	135 201
7	phase ground		135 202
8	Connecting cable 50 mm ² , 2 m long	1.480	135 208
			135 209
9	Terminal bolt M 8 x 12 K 4	0.010	170 871

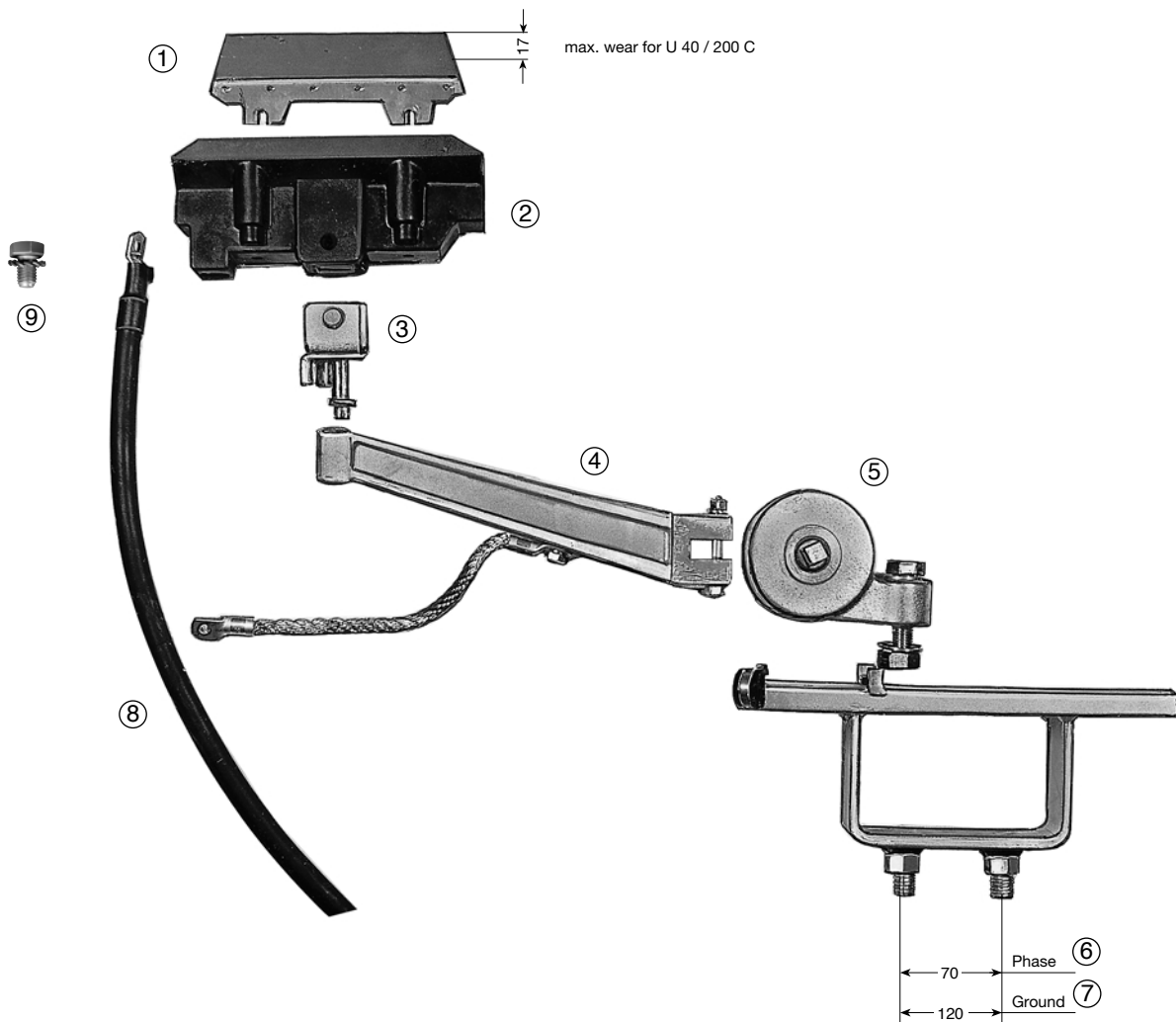



EXAMPLE FOR ORDERING U 40

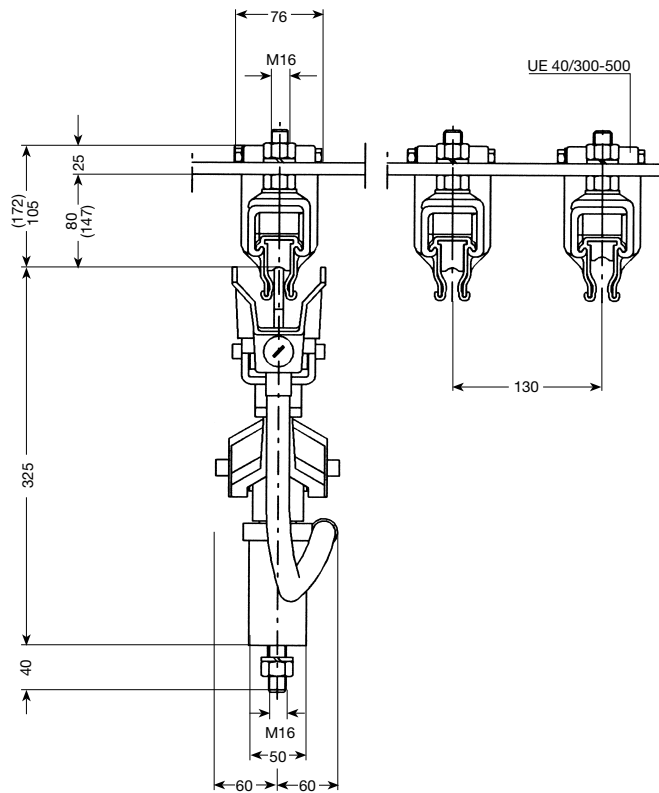

Dimensions in brackets include insulators type GH 80/UAS 40 with rail holder UAK 40.

Example for Ordering 250 m power supply system, 3 pole + ground, 1000 A

Qty.	Description		Type	Cat.-No.
120	VAHLE unipole insulated conductors, 6 m long	phase	U 40/500 C-6	134 366
3	VAHLE unipole insulated conductors, 2 m long	phase	U 40/500 C-2	134 362
40	VAHLE unipole insulated conductors, 6 m long	ground	U 40/300 C-6*	136 126
1	VAHLE unipole insulated conductor, 2 m long	ground	U 40/300 C-2*	136 122
12	Expansion sections, 2 m long	phase	UDV 40/500 C	134 730
4	idem	ground	UDV 40/300 C*	134 700
160	Rigid joints		UV 40/300-500	135 384
8	Feed terminals		UE 40/300-500	135 386
40	Locating clamps		USK 40 K 4	134 080
8	End caps		UK 40	134 060
504	Insulated hangers		UAM 40	134 040
6	Current collectors	phase	UDST 400	134 320
1	Current collector	ground	UDST 400*	134 330

Earthing spider system, 4 pole, for insulated conductors serves for earthing and short-circuiting the phase conductors with the ground conductor in the case of maintenance work.

The system consists of terminal clamps for the conductors and copper wire ropes and is designed for a short-circuit current of max. 40 kA.

Earthing spider system cannot be used together with compact conductor arrangement.

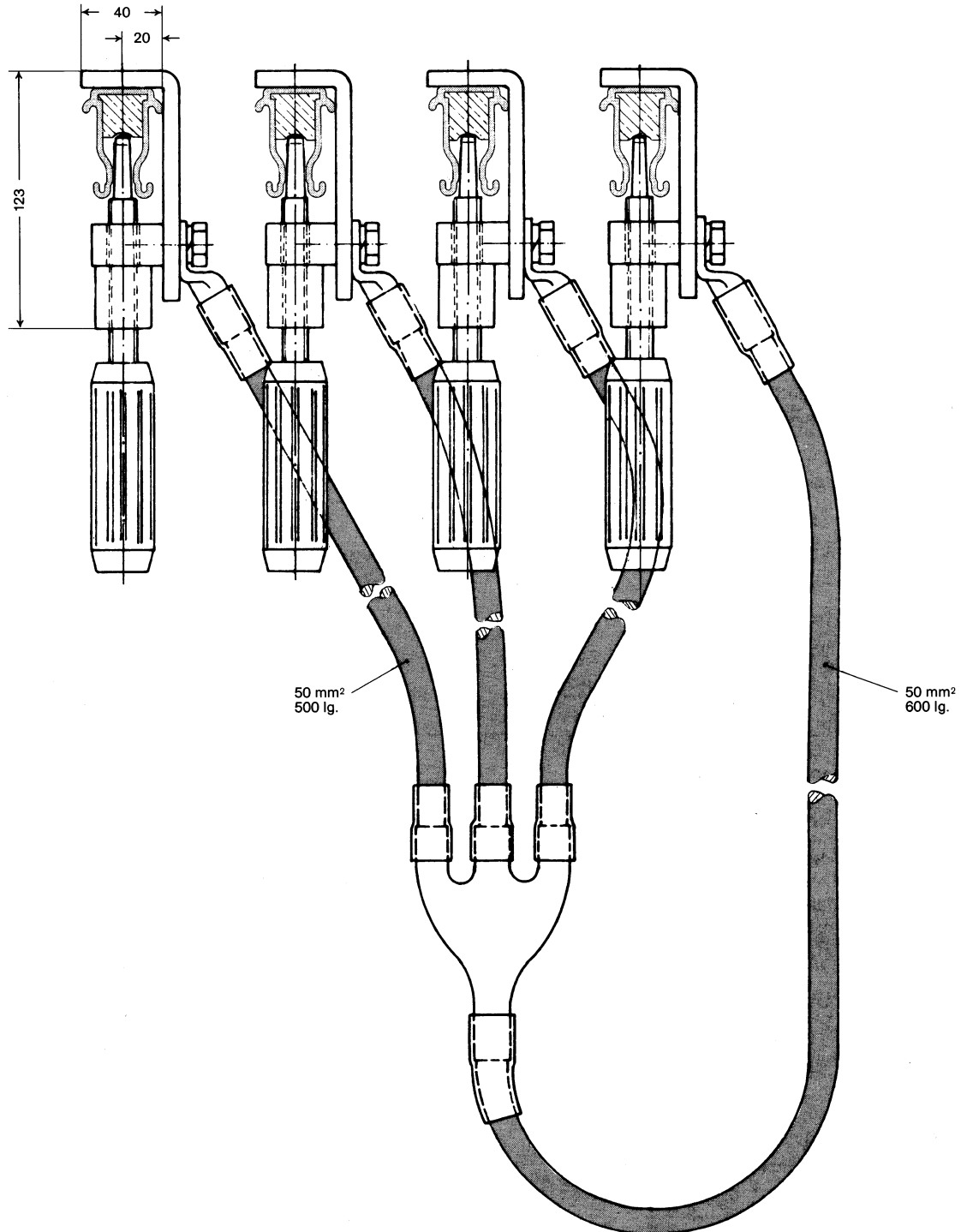

Type	for conductor type	Copper section of wire rope	Cat.-No.
EUK 20	U 20	50 mm ²	120 361
EUK 30-40	U 30, U 40	50 mm ²	130 035



QUESTIONNAIRE

Address: _____

Customer _____

1. Type of crane/machine to be electrified: _____

2. Voltage: _____ Volts: _____ Phases: _____ c/s: _____

3. Length of conductor system: _____

4. Number of conductors: _____ power lines: _____ control lines: _____ neutral (ground): _____

5. Indoor: _____ Outdoor: _____

6. Special site conditions (humidity, dust, chemical influences etc.): _____

7. Temperature conditions: _____ °C min. _____ °C max.

8. Number and position of feeder points: _____

9. Mounting position envisaged? _____
(prints and sketches should be submitted whenever obtainable)

10. Number of cranes / machines electrified from the one system: _____

11. Ampere load of each crane/machine: _____
(use table on reverse page)

12. Travelling speed of machinery: _____

Remarks: _____

Please submit prints or sketches for curved tracks, discontinuous circuits etc.



To our nearest local agency

Date:

Motordata	Crane/Mobile Equipment No. 1			Crane/Mobile Equipment No. 2			Crane/Mobile Equipment No. 3		
	Power kW/HP	Current Amps	Duty-Factor %	Power kW/HP	Current Amps	Duty-Factor %	Power kW/HP	Current Amps	Duty-Factor %
Hoist motor									
Auxiliary hoist									
Travel motor – main-trolley									
Travel motor – aux.-trolley									
Main travel									
Slewing									
Luffing									

Mark with * any motors that may be in simultaneous operation.

Further particulars: _____



TYPICAL INSTALLATIONS

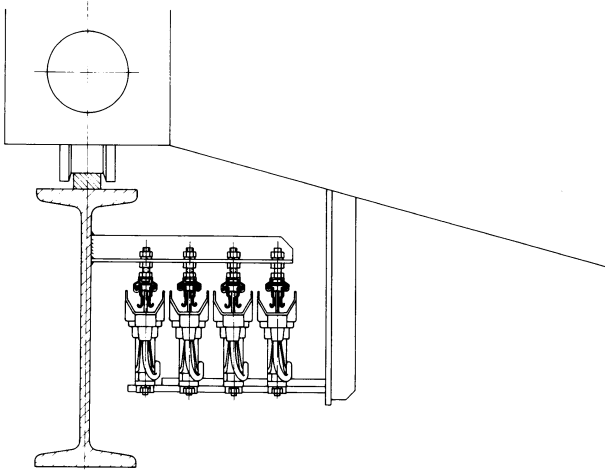

Suspended mounting of 4-pole system.

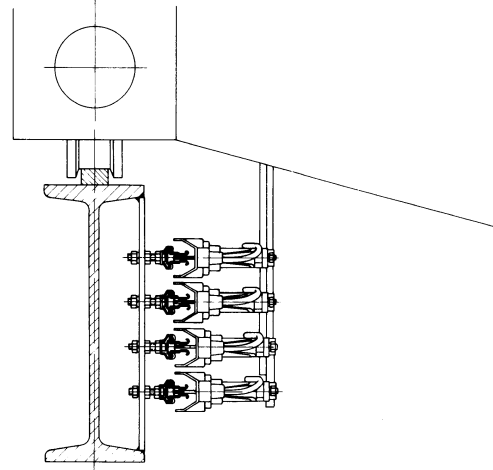

Lateral mounting of 4-pole system, using insulated conductors with type index CH.

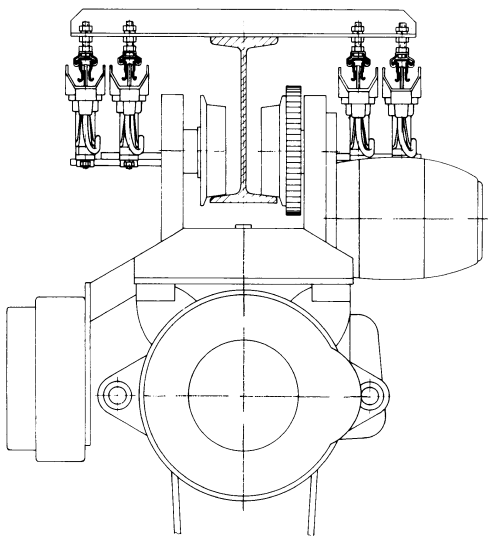

Equally balanced conductor arrangement for monorail hoist.

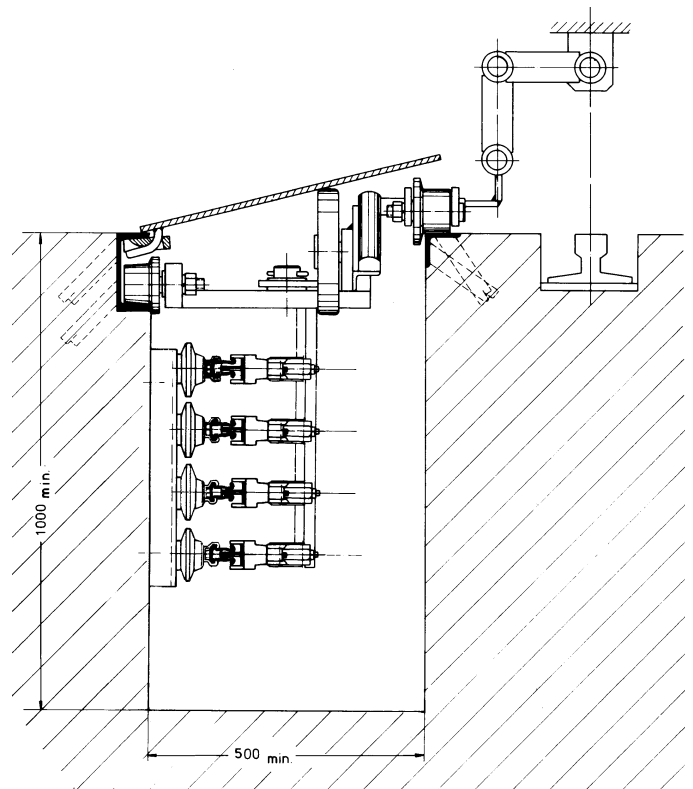

Insulated conductors U 30 in VAHLE trench system.