

Moeller HPL0211-2004/2005

**DS4 soft starters and semiconductor contactors**

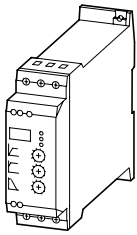

**DM4 soft starters**

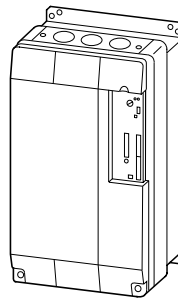

DM4 soft starters

<b>System overview</b>	<b>Page</b> 17/2
<b>Description</b>	
DS4 semiconductor contactors and soft starters	17/3
<b>DS4 selection data</b>	17/4
<b>DS4 semiconductor contactors and soft starters</b>	
DS4 semiconductor contactors	17/6
DS4 semiconductor contactors and soft starters	17/6
DS4 soft starters	17/6
<b>Engineering</b>	
Standard connections, DS4	17/9
<b>Technical data</b>	17/30
<b>Dimensions</b>	17/46

<b>System overview</b>	<b>Page</b> 17/12
<b>Description</b>	
DM4 soft starters	17/14
DE4-KEY-2 keypad	17/15
RS 232/RS 485 serial interface	17/15
PROFIBUS DP communication module	17/16
Suconet K communication module	17/16
<b>Selection data</b>	
DM4 soft starters	17/17
Assigned switching and protective elements	17/18
<b>DM4 soft starters</b>	
DM4 basic units	17/22
DE4-KEY-2 keypad	17/22
<b>Networking and communication modules</b>	
Modules	17/23
<b>Accessories</b>	
Semiconductor fuses, fuse base	17/23
<b>Engineering</b>	
Wiring examples	17/24
<b>Technical data</b>	17/38
<b>Dimensions</b>	17/49



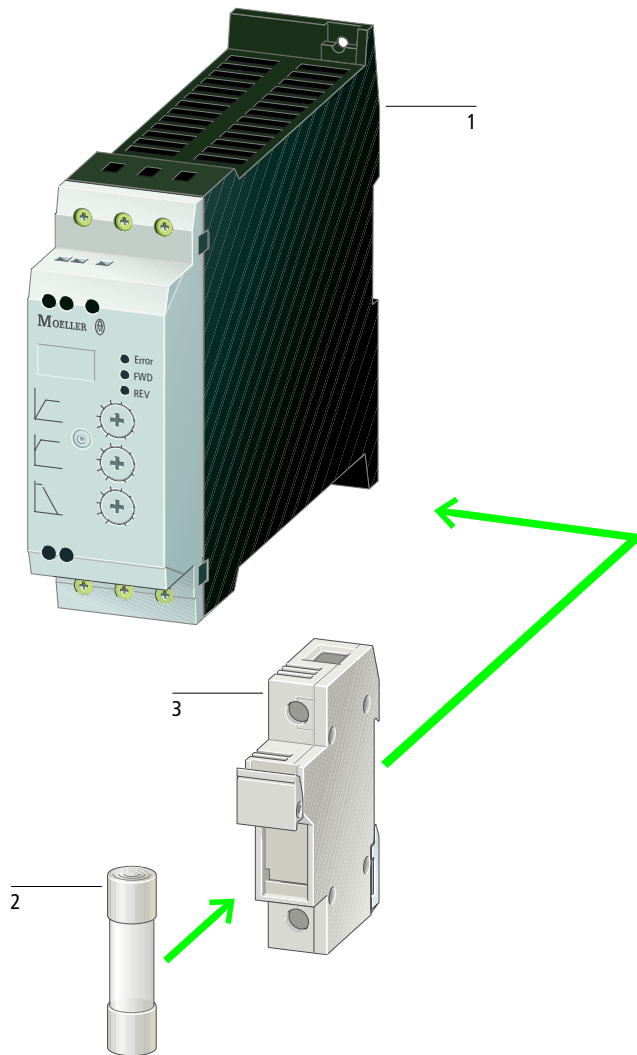

**Basic units**

**DS4-140 semiconductor contactors** 1  
Current range 10 – 50 A at 110 – 500 V

**DS4-340-M (R) semiconductor contactors and soft starters** 1  
Semiconductor contactors for resistive loads  
11 – 41 A at 110 – 500 V

DOL starting method for reduced transients

Soft starter for three-phase motors  
Rated power 2.2 to 11 kW at 400 V

Rated voltage 110 – 500 V with and without  
built-in reversing contactor function

Asymmetric trigger control for clearly improved  
true run behaviour

Selection data → Page 17/4

Ordering information → Page 17/6

**DS4-340-MX (R) soft starter** 1  
Soft starter for three-phase motors

Rated power 7.5 to 22 kW at 400 V

Rated voltage 110 – 500 V with and without  
built-in reversing contactor function

Asymmetric trigger control for clearly improved  
true run behaviour

Selection data → Page 17/4

Ordering information → Page 17/6

**Superfast semiconductor fuses** 2  
Fuses for protecting the DS4 from short circuits  
or to achieve type "2" coordination for external  
surface mounting

Selection data → Page 17/4

Ordering information → Page 17/7

**Fuse bases** 3

Selection data → Page 17/4

Ordering information → Page 17/7



## DS4 semiconductor contactors and soft starters

Moeller HPL0211-2004/2005

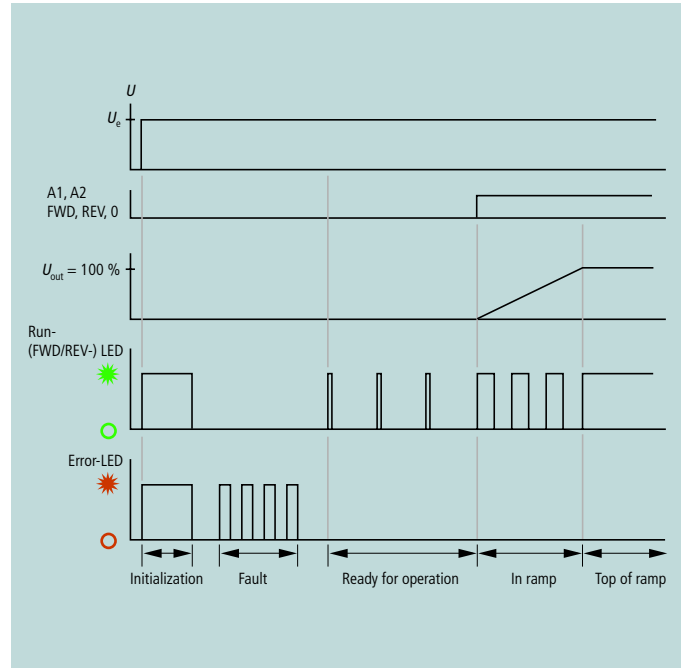

## Type overview

## Single-phase semiconductor contactors:

- DS4-140-...-H

## Semiconductor contactors/soft starters for three-phase loads:

- DS4-340-...-M(R)

## Soft starters for three-phase loads:

- DS4-340-...-MX(R)

## Application

## DS4-140-...-H

Single-phase semiconductor contactors from 10 – 50 A for resistive loads

## Application examples:

- All types of temperature control. High switching frequencies do not present problems for a semiconductor contactor. Two-position temperature controllers operate with higher precision and enhance product quality.
- Lighting control systems. Semiconductor contactors switch quickly and silently.
- Traffic light control systems.

## DS4-340-...-M(R)

Two-phase-controlled semiconductor contactors/soft starters with 2.2 to 11 kW for three-phase loads.

DS4-340-11K-M can be operated with an external bypass contactor. At the same load cycle as for the MX(R) versions, motors up to 22 kW can be operated.

The devices of this series can be used as semiconductor contactors and as soft starters. Devices with type suffix "R" are equipped with an additional built-in reversing function.

When used as a semiconductor contactor, DOL control ensures that motors are switched on at the optimum time to suppresses inrush transients, which cause current and torque oscillations of up to twenty times the motor's rated current.

## Application examples:

- Frequent and silent switching of motors including reversing
- All types of temperature control. High switching frequencies do not present problems for semiconductor contactors. Two-position temperature controllers operate with higher precision and enhance product quality.
- Lighting control systems. Semiconductor contactors switch quickly and silently. When used as a soft starter, the DC component, which normally occurs in two-phase control, is suppressed with a special actuation method. The motor therefore behaves as with three-phase control. The DS4 can therefore be used to start applications that previously required three-phase soft starters. The high overload capability of the M(R) versions means that high moments of inertia do not present any problems for frequent starting and soft starting.

## Application examples:

- Replacement of star-delta combinations
- Replacement of reversing contactor combinations
- Pump drives: Soft starting prevents sudden pressure surges. Reduces mechanical loading of the entire system and extends its lifespan.
- Fan drives: Soft starting prevents drive belt slippage and premature wear. The lifespan of the entire system is extended.
- Conveyor belts: the belt starts smoothly and the transported goods do not fall over. Mechanical wear of the entire system is reduced and its lifespan increased.

## DS4-340-...-MX(R)

Two-phase controlled soft starter with internal bypass for three-phase motors 7.5 – 15 kW.

Devices with type suffix "R" are equipped with an additional built-in reversing function

(7.5 – 15 kW). When used as a soft starter, the DC component, which normally occurs in two-phase control, is suppressed with a special actuation method. The DS4 can therefore be used to start applications which previously required three-phase soft starters. The DS4 versions MX(R) are designed for normal duty cycle requirements.

## Application examples:

- Replacement of star-delta combination
- Replacement of reversing contactor combinations
- Pump drives: Soft starting prevents sudden pressure surges. Reduces mechanical loading of the entire system and extends its lifespan.
- Fan drives: Soft starting prevents drive belt slippage and premature wear. The lifespan of the entire system is extended.
- Conveyor belts: The belt starts smoothly and the transported goods do not fall over. Mechanical wear of the entire system is reduced and its lifespan increased.



Type	Rated operational current <sup>1)</sup>  I A	Semiconductor contactor function			Overload protection when using a motor-protective circuit-breaker without built-in overload function <sup>4)</sup>
		Line protection <sup>3)</sup>			
		230 V	400 V	500 V	
<b>Semiconductor contactor for single-phase power supply (resistive load)</b>					
DS4-140-010-H	10	FAZ-B10/1	2 × FAZ-B10/1	PKM0-10 (+ CL-PKZ0)	Z00-10
DS4-140-020-H	20	FAZ-B20/1	2 × FAZ-B20/1	PKM0-20 (+ CL-PKZ0)	Z00-24 (+ EZ00)
DS4-140-030-H	30	FAZ-B32/1	2 × FAZ-B32/1	PKZ2 + M-32-PKZ2 (+ CL-PKZ2)	Z1-40 (+ EZ1)
DS4-140-050-H	50	FAZ-B50/1	2 × FAZ-B50/1	NZM7-63N-OBI	Z1-63(+ EZ1)

Notes  
<sup>1)</sup> Rated operational current relative to the specified load cycle  
<sup>2)</sup> Semiconductor fuses are required only for type "2" coordination; max. short-circuit current 100 kA.

Type	Motor rating at 400 V  P kW	Rated operational current <sup>5)</sup>			Soft starter function		
		Device	Motor	Cable <sup>6)</sup>	Line protection <sup>8)</sup>	Mains contactor	Overload relay <sup>10)</sup>
		I A	I <sub>e</sub> A	I A			
<b>Soft starter for three-phase power supply, low operating frequency (5 s, 3 × I<sub>e</sub>, 10 starts)</b>							
DS4-340-2K2-M(R)(-DC)	2.2	6	5	7	PKM0-6.3 (+ CL-PKZ0)	DIL00M	Z00-6
DS4-340-4K0-M(R)	4	9	8.5	10	PKM0-10 (+ CL-PKZ0)	DIL00M	Z00-10
DS4-340-5K5-M(R)	5.5	12	11.3	14	PKM0-16 (+ CL-PKZ0)	DIL00AM	Z00-16
DS4-340-7K5-M(R)	7.5	16	15.2	18	PKM0-16 (+ CL-PKZ0)	DIL0M	Z00-16
DS4-340-11K-M(R)	11	23	21.7	27	PKM0-25 (+ CL-PKZ0)	DIL0AM	Z00-24 (+ EZ00)
DS4-340-7K5-MX(R)	7.5	16	15.2	18	PKM0-16 (+ CL-PKZ0)	DIL0M	Z00-16
DS4-340-11K-MX(R)	11	23	21.7	27	PKM0-25 (+ CL-PKZ0)	DIL0AM	Z00-24 (+ EZ00)
DS4-340-15K-MX(R)	15	31	29.3	37	PKZ2+M-32-PKZ2 (+ CL-PKZ2)	DIL1M	Z1-40 (+ EZ1)
DS4-340-11K-M + DIL2M(230V,50HZ)	22	46	41	53	NZM7-63N-OBI	DIL2M	Z1-57 (+ EZ1)
<b>Soft starter for three-phase power supply, high operating frequency (5 s, 6 × I<sub>e</sub>, 20 starts)</b>							
DS4-340-2K2-M(R)(-DC)	2.2	6	5	9	PKM0-10 (+ CL-PKZ0)	DIL00M	ZEV + ZEV-XSW-25
DS4-340-4K0-M(R)	4	9	8.5	14	PKM0-16 (+ CL-PKZ0)	DIL00M	ZEV + ZEV-XSW-25
DS4-340-5K5-M(R)	5.5	12	11.3	19	PKM0-20 (+ CL-PKZ0)	DIL00AM	ZEV + ZEV-XSW-25
DS4-340-7K5-M(R)	7.5	16	15.2	25	PKM0-25 (+ CL-PKZ0)	DIL0M	ZEV + ZEV-XSW-25
DS4-340-11K-M(R)	11	23	21.7	36	NZM7-40N-OBI	DIL1M	ZEV + ZEV-XSW-65
<b>Semiconductor contactor for three-phase power supply, high operating frequency (0.5 s, 6 × I<sub>e</sub>, 600 starts)</b>							
DS4-340-2K2-M(R)(-DC)	2.2	6	5	12	PKM0-10 (+ CL-PKZ0)	DIL00M	ZEV + ZEV-XSW-25
DS4-340-4K0-M(R)	4	9	8.5	18	PKM0-20 (+ CL-PKZ0)	DIL00AM	ZEV + ZEV-XSW-25
DS4-340-5K5-M(R)	5.5	12	11.3	24	PKM0-25 (+ CL-PKZ0)	DIL0M	ZEV + ZEV-XSW-25
DS4-340-7K5-M(R)	7.5	16	15.2	32	NZM7-40N-OBI	DIL0AM	ZEV + ZEV-XSW-65
DS4-340-11K-M(R)	11	23	21.7	46	NZM7-63N-OBI	DIL1M	ZEV + ZEV-XSW-65
<b>Semiconductor contactor for AC-51 applications (1 s, 1.5 × I<sub>e</sub>, 600 starts/switch operations)</b>							
DS4-340-2K2-M(R)(-DC)		11			PKM0-16 (+ CL-PKZ0)	DIL00M	
DS4-340-4K0-M(R)		17			PKM0-20 (+ CL-PKZ0)	DIL00M	
DS4-340-5K5-M(R)		22			PKM0-25 (+ CL-PKZ0)	DIL0M	
DS4-340-7K5-M(R)		29			PKZM4-32	DIL0M	
DS4-340-11K-M(R)		41			PKZM4-40	DIL1M	

Notes  
<sup>5)</sup> Rated operational current relative to the specified load cycle.  
<sup>6)</sup> Indicates the current for which the supply cable must be dimensioned at the specified switching duty and motor current. At higher motor currents and different switching duty (operating frequency, overcurrent, overcurrent time, DF), this value changes and must then be adapted accordingly.  
<sup>7)</sup> Semiconductor fuses are required only for type "2" coordination; max. short-circuit current 100 kA.  
<sup>8)</sup> Max. short-circuit current as per technical specifications of used circuit-breaker.

Mains contactor (optional)	Semiconductor fuse (optional, in addition to the protective devices for type "1" coordination, required for type "2" coordination) <sup>2)</sup>	
	Fuses	Fuse holders
DIL00M	1 × 50.179.06-16	1 × 51.063.04
DIL00M	1 × 50.124.06-32	1 × 51.058.04
DIL00M	1 × 50.140.06-50	1 × 51.060.04
DIL00M	1 × 50.140.06-80	1 × 51.060.04

<sup>3)</sup> Max. short-circuit current as per technical specifications of used circuit-breaker.  
<sup>4)</sup> For resistive loads, overload protection is not usually required

Semiconductor fuse (optional, in addition to the protective devices for type "1" coordination, required for type "2" coordination) <sup>7)</sup>		DC braking unit					
Fuses	Fuse holders	Hilger & Kern Frenomat/Frenostat					
Number × type	Number × type	Recommended type at 400 V mains voltage	Soft starter output contactor <sup>11)</sup>	Line protection	Mains choke <sup>12)</sup>	Braking contactor	Standstill detection fuse <sup>13)</sup>
3 × 50.140.06-50	3 × 51.060.04	Frenomat-6000.0185	DILEM	PKZM0-10 (+ CL-PKZ0)	–	DIL00M	FAZ-B4/1-HI
3 × 50.140.06-63	3 × 51.060.04	Frenomat-6000.0185	DILEM	PKZM0-16 (+ CL-PKZ0)	–	DIL00M	FAZ-B4/1-HI
3 × 50.140.06-80	3 × 51.060.04	Frenostat-6000.0304	DILEM	PKZM0-20 (+ CL-PKZ0)	–	Internal	FAZ-B4/1-HI
3 × 20.282.20-125	3 × 21.189.01	Frenostat-6000.0316	DILEM	PKZM0-25 (+ CL-PKZ0)	External	DIL0M	FAZ-B4/1-HI
3 × 20.282.20-160	3 × 21.189.01	Frenostat-6000.0247	DIL0M	PKZM4-40	Internal	DIL0AM	FAZ-B4/1-HI
3 × 50.140.06-63	3 × 51.060.04	Frenostat-6000.0316	DILEM	PKZM0-25 (+ CL-PKZ0)	External	Internal	FAZ-B4/1-HI
3 × 50.140.06-80	3 × 51.060.04	Frenostat-6000.0247	DIL0M	PKZM4-40	Internal	DIL0AM	FAZ-B4/1-HI
3 × 20.282.20-125	3 × 21.189.01	Frenostat-6000.0247	DIL0M	PKZM4-50	Internal	DIL1M	FAZ-B4/1-HI
3 × 20.282.20-160	3 × 21.189.01	Frenostat-6000.0248	DIL1M	PKZM4-63	Internal	DIL2M	FAZ-B4/1-HI
3 × 50.140.06-50	3 × 51.060.04	Frenomat-6000.0185	DILEM	PKZM0-10 (+ CL-PKZ0)	–	DIL00M	FAZ-B4/1-HI
3 × 50.140.06-63	3 × 51.060.04	Frenomat-6000.0185	DILEM	PKZM0-16 (+ CL-PKZ0)	–	DIL00M	FAZ-B4/1-HI
3 × 50.140.06-80	3 × 51.060.04	Frenostat-6000.0304	DILEM	PKZM0-20 (+ CL-PKZ0)	–	Internal	FAZ-B4/1-HI
3 × 20.282.20-125	3 × 21.189.01	Frenostat-6000.0316	DIL0M	PKZM0-25 (+ CL-PKZ0)	External	DIL0M	FAZ-B4/1-HI
3 × 20.282.20-160	3 × 21.189.01	Frenostat-6000.0247	DIL0M	PKZM4-40	Internal	DIL0AM	FAZ-B4/1-HI
3 × 50.140.06-50	3 × 51.060.04	Frenomat-6000.0185	DILEM	PKZM0-10 (+ CL-PKZ0)	–	DIL00M	FAZ-B4/1-HI
3 × 50.140.06-63	3 × 51.060.04	Frenomat-6000.0185	DILEM	PKZM0-16 (+ CL-PKZ0)	–	DIL00M	FAZ-B4/1-HI
3 × 50.140.06-80	3 × 51.060.04	Frenostat-6000.0304	DIL0M	PKZM0-20 (+ CL-PKZ0)	–	Internal	FAZ-B4/1-HI
3 × 20.282.20-125	3 × 21.189.01	Frenostat-6000.0316	DIL0M	PKZM0-25 (+ CL-PKZ0)	External	DIL0M	FAZ-B4/1-HI
3 × 20.282.20-160	3 × 21.189.01	Frenostat-6000.0247	DIL1M	PKZM4-40	Internal	DIL0AM	FAZ-B4/1-HI
3 × 50.140.06-50	3 × 51.060.04						
3 × 50.140.06-63	3 × 51.060.04						
3 × 50.140.06-80	3 × 51.060.04						
3 × 20.282.20-125	3 × 21.189.01						
3 × 20.282.20-160	3 × 21.189.01						

<sup>9)</sup> If the control section is configured so that the control signal is inhibited before the mains contactor is disabled in the event of an Emergency-Stop, the contactors in the "Bypass contactor" column can also be used as mains contactors.  
<sup>10)</sup> Alternatively, a motor-protective circuit-breaker with built-in overload protection can be used (e.g. PKZM0, NZM without the "-OBI" extension).  
<sup>11)</sup> If a DC braking unit is used, the soft starter's output must be isolated with this contactor before braking.  
<sup>12)</sup> If external, included as standard.  
<sup>13)</sup> If a measuring line with a cross-section ≤ 1.5 mm<sup>2</sup> is used, the fuse can be omitted.

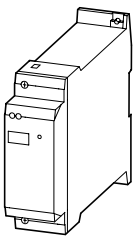
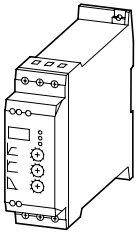
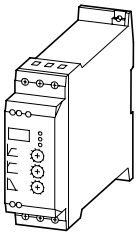

		Rated operational voltage	Rated operational current		Rated power for three-phase motors at 3 AC 400 V	Type Article no.	Price See Price List	Std. pack
		$U_e$	AC—51	AC—53	$P$			
		V AC	$I_e$ A	$I_e$ A	kW			
<b>DS4 semiconductor contactors</b>								
	Semiconductor contactors for single-phase loads	110 – 500	10	–	–	DS4-140-010-H 210986		1 off
		110 – 500	20	–	–	DS4-140-020-H 210987		
		110 – 500	30	–	–	DS4-140-030-H 210988		
		110 – 500	50	–	–	DS4-140-050-H 210989		
<b>DS4 semiconductor contactors and soft starters</b>								
	Semiconductor contactors and soft starters for three-phase loads	110 – 500	11	6	2.2	DS4-340-2K2-M 210990		1 off
		110 – 500	17	9	4	DS4-340-4K0-M 210991		
		110 – 500	22	12	5.5	DS4-340-5K5-M 210992		
		110 – 500	29	16	7.5	DS4-340-7K5-M 210993		
		110 – 500	41	23	11	DS4-340-11K-M 225125		
	Semiconductor contactors and soft starters for three-phase loads, fast control signal inputs, DC actuation only	110 – 500	11	6	2.2	DS4-340-2K2-M-DC 235293		
	Semiconductor contactors and soft starters for three-phase loads with reversing function	110 – 500	–	6	2.2	DS4-340-2K2-MR 210998		
		110 – 500	–	9	4	DS4-340-4K0-MR 210999		
		110 – 500	–	12	5.5	DS4-340-5K5-MR 211000		
		110 – 500	–	16	7.5	DS4-340-7K5-MR 211001		
		110 – 500	–	23	11	DS4-340-11K-MR 225128		
	<b>DS4 soft starters</b>							
	Soft starters for three-phase loads	110 – 500	–	16	7.5	DS4-340-7K5-MX 231954		1 off
		110 – 500	–	23	11	DS4-340-11K-MX 210994		
		110 – 500	–	31	15	DS4-340-15K-MX 210995		
		110 – 500	–	46	22	DS4-340-11K-M 225125 + DIL2M(230V50HZ) 046566		
	Soft starters for three-phase loads with reversing function	110 – 500	–	16	7.5	DS4-340-7K5-MXR 211002		
		110 – 500	–	23	11	DS4-340-11K-MXR 231955		
		110 – 500	–	31	15	DS4-340-15K-MXR 211003		
		110 – 500	–	46	22			



Moeller HPL0211-2004/2005

Rated current A	Max. heat dissipation $P_v$ W	Frame size/critical dimension mm	For use with	Type Article no.	Price See Price List	Std. pack
<b>Fuses</b>						
Fuses for soft starters and semiconductor contactors						
16	4.4	10 × 38	DS4-140-010-H	<b>50.179.06-16</b> 232077		10 off
32	9.5	14 × 51	DS4-140-020-H	<b>50.124.06-32</b> 232078		
50	15	22 × 58	DS4-140-030-H DS4-340-2K2-M DS4-340-2K2-MR DS4-340-2K2-M-DC	<b>50.140.06-50</b> 232079		
63	16	22 × 58	DS4-340-4K0-M DS4-340-4K0-MR DS4-340-7K5-MX DS4-340-7K5-MXR	<b>50.140.06-63</b> 232080		
80	18	22 × 58	DS4-140-050-H DS4-340-5K5-M DS4-340-5K5-MR DS4-340-11K-MX DS4-340-11K-MXR	<b>50.140.06-80</b> 232081		
125	26	80	DS4-340-7K5-M DS4-340-7K5-MR DS4-340-15K-MX DS4-340-15K-MXR	<b>20.282.20-125</b> 232087		6 off
160	32	80	DS4-340-11K-M DS4-340-11K-MR DS4-340-11K- M+DIL2M(230V,50HZ)	<b>20.282.20-160</b> 258244		6 off
Fuse bases for semiconductor fuses						
–	–	10 × 38	Semiconductor fuses 50.179.06-...	<b>51.063.04</b> 232082		12 off
–	–	14 × 51	Semiconductor fuses 50.124.06-...	<b>51.058.04</b> 232083		10 off
–	–	22 × 58	Semiconductor fuses 50.140.06-...	<b>51.060.04</b> 232084		6 off
–	–	S00	Semiconductor fuses 20.282.20-...	<b>21.189.01</b> 232064		5 off



# 17/8 DS4 semiconductor contactors and soft starters

## For three-phase motors and single-phase AC loads

Moeller HPL0211-2004/2005

	DS4-140-H	DS4-340-M(-DC)	DS4-340-MR	DS4-340-MX	DS4-340-MXR
<b>Power section</b>	Thyristors in one phase	Thyristors in two phases	Thyristors in two phases, internal phase reversal for reversing function	Thyristors in two phases, bypass relay	Thyristors in two phases, internal phase reversal for reversing function, bypass relay
Mains supply voltage $U_{LN}$ (45 – 65 Hz $\pm$ 0 %)	110 – 500 V AC				
Control voltage	24 V DC, 110 – 240 V AC				
Rated operational current					
AC-51 (resistive load)	10 – 50 A	–	–	–	–
AC-53 (inductive load)	–	6 A – 23 A (41 A)	6 A – 23 A	16 – 31 A	16 – 31 A
Recommended motor rating	–	2.2 kW – 11 kW (22 kW)		7.5 – 15 kW	
Overload cycle	Operating frequency limited only by mains frequency	AC-53 a : 6 – 0.5 : 99 – 600 <sup>1)</sup> AC-53 a : 6 – 5 : 99 – 20 <sup>1)</sup> DS4-11K-M also: 49 A : AC-53 b : 3 – 5 : 360		AC-53 b : 3 – 5 : 360 <sup>1)</sup>	
Built-in bypass relay	–	–	–	Yes	Yes
Reversing contactor function	–	–	Yes	–	Yes
Standards	IEC/EN 60947-4-3	IEC/EN 60947-4-2; IEC/EN 60947-4-3	IEC/EN 60947-4-2	IEC/EN 60947-4-2	
Degree of protection	IP 20 <sup>2)</sup>				
Pick-up time AC/DC	10/10 ms	115/95 (-DC : 45)	115/95	115/95	115/95
Drop-out time AC/DC	25/20 ms	165/165 (-DC : 45)	165/165	165/165	165/165
Changeover time for reversing contactors (transition from 100 % FWD to 100 % REV)	–	–	> 300 ms (semiconductor contactor) > 1 s (soft start)	–	> 1 s (soft start)
<b>Fields of application</b>					
Single-phase loads (heaters, lamps, electroplating)	●				
Three-phase loads (heaters, lamps, electroplating)		●	●		
Three-phase motors		●	●	●	●
<b>Functions</b>					
Fast switching (semiconductor contactor)	●	●	●		
Soft start function		●	●	●	●
Reversing contactor function			●		●
Suppression of closing transients on motors		●			
Suppression of DC components on motors		●			
Potential isolation between power section and control section	●				
Approvals	UL, CSA	UL available soon			
Storage temperature	-25 to +55 °C				
Operating temperature	0 to 40 °C				
Altitude	Up to 1000 m a.s.l.				

### Notes

● Included as standard

- Overload cycle to IEC/EN 60947-4-2 or -3  
AC-53 a : Operation in drive mode without bypass  
AC-53 b : Operation in drive mode with semiconductor bypass after run-up  
AC-51 : Operation of resistive or slightly inductive loads (heaters, lamps)  
The first appended number pair indicates the overcurrent in multiples of the rated current and the overcurrent time:  
i.e. "6 – 0.5" means "six times rated current for 0.5 seconds".  
The second appended number pair indicate the switching duty:  
For AC-53 a : "99 – 600" means a duty factor of 99 % at 600 starts per hour  
For AC-53 b : "360" is the time between two starts in seconds.
- Power terminals partly IP 00, → Technical data



Moeller HPL0211-2004/2005

## DS4-140 single-phase semiconductor contactors

Standard connection

Actuation

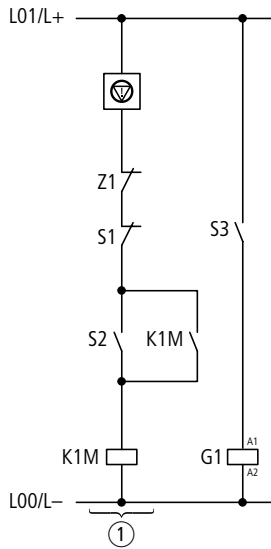

Connection to a single-phase 230 V mains

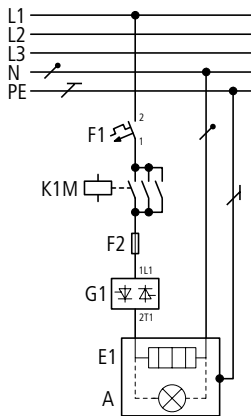

Connection to a single-phase 400 V mains

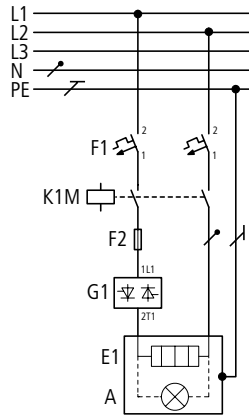

Connection to a single-phase 500 V mains

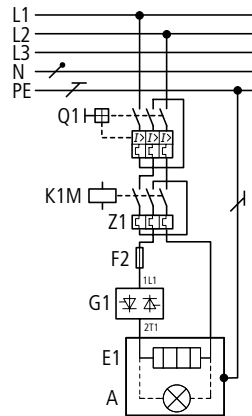

## DS4-340-M(R) three-phase semiconductor contactors/soft starters

Standard connection, semiconductor contactor (actuator)

Actuation

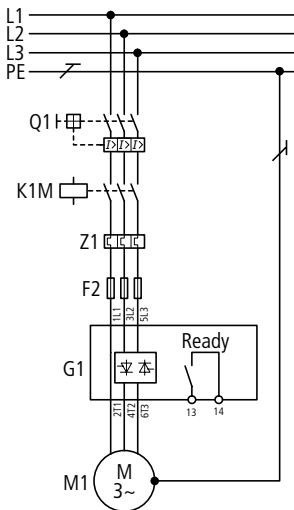
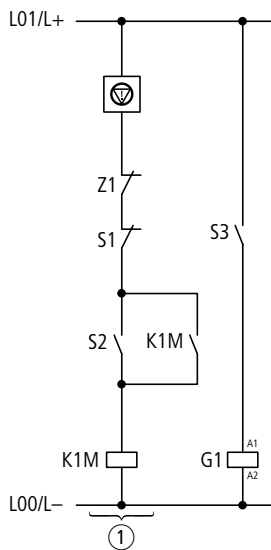

- F1, Q1 = line protection
- K1M = mains contactor (optional)
- Z1 = overload relay
- F2 = semiconductor fuse for type "2" coordination, in addition to F1, Q1 (optional)
- G1 = semiconductor contactor
- E1 = load
- S1 = Off
- S2 = On
- S3 = Start/Stop
- ① = control arm with K1M (optional)
- ⊖ = Emergency-Stop





DS4-340-M(X)(R) three-phase semiconductor contactors/soft starters

Standard connection (switch, PLC output)

Standard connection

Actuation without reversing function

Actuation with reversing function

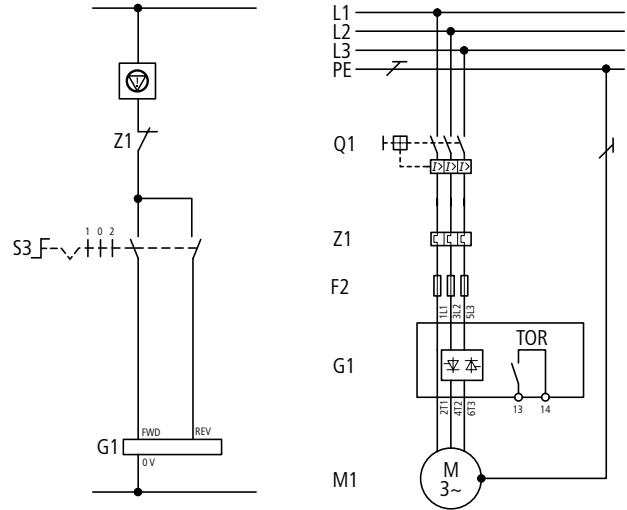
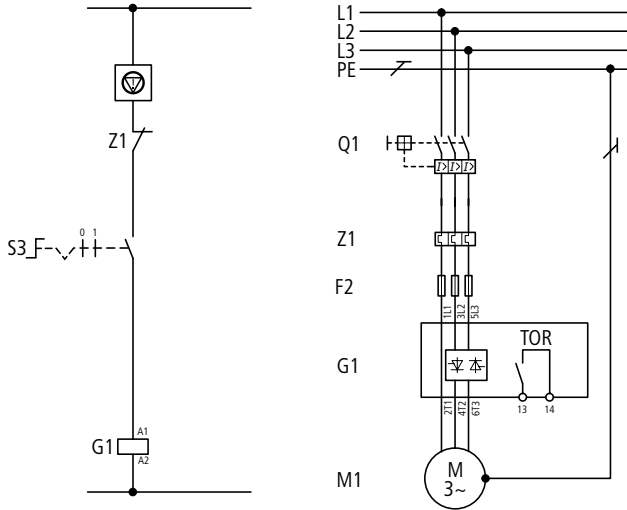

0: Off/soft stop  
1: Start/soft start

0: Off/soft stop  
1: FWD  
2: REV

Power section and actuation (DS4 with built-in bypass)

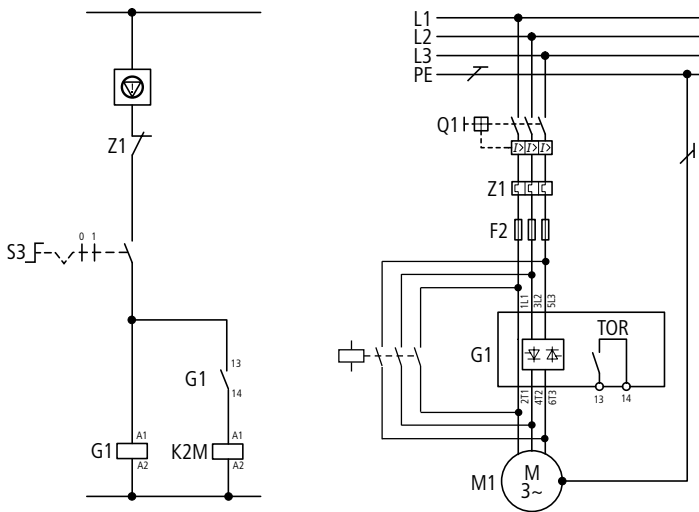

- Q1 = line protection
- Z1 = overload relay
- F2 = semiconductor fuse for type "2" coordination, in addition to Q1 (optional)
- G1 = semiconductor contactor
- ⊖ = Emergency-Stop



Moeller HPL0211-2004/2005

### DS4-340-M(X)(R) three-phase semiconductor contactors/soft starters

Standard connection

Actuation without reversing function

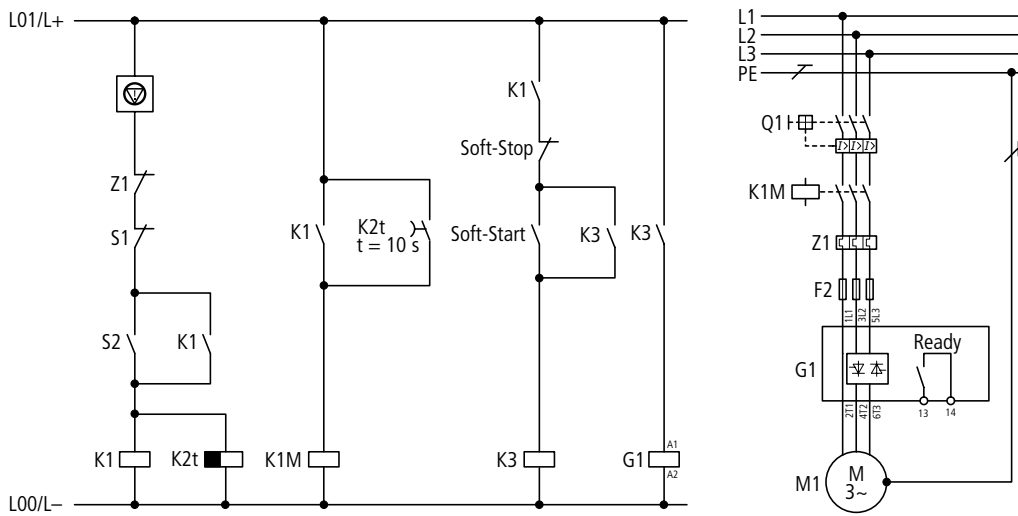

Standard connection

Actuation with reversing function

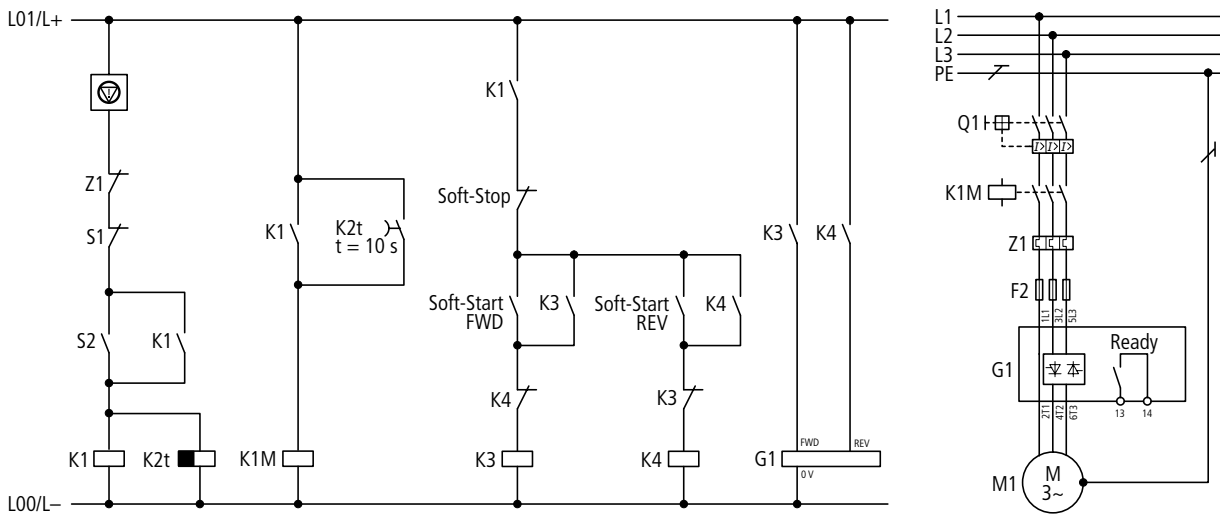

- Q1 = line protection
- K1M = mains contactor (optional)
- Z1 = overload relay
- F2 = semiconductor fuse for type "2" coordination, in addition to Q1 (optional)
- G1 = semiconductor contactor
- S1 = Off
- S2 = On
- ⊘ = Emergency-Stop



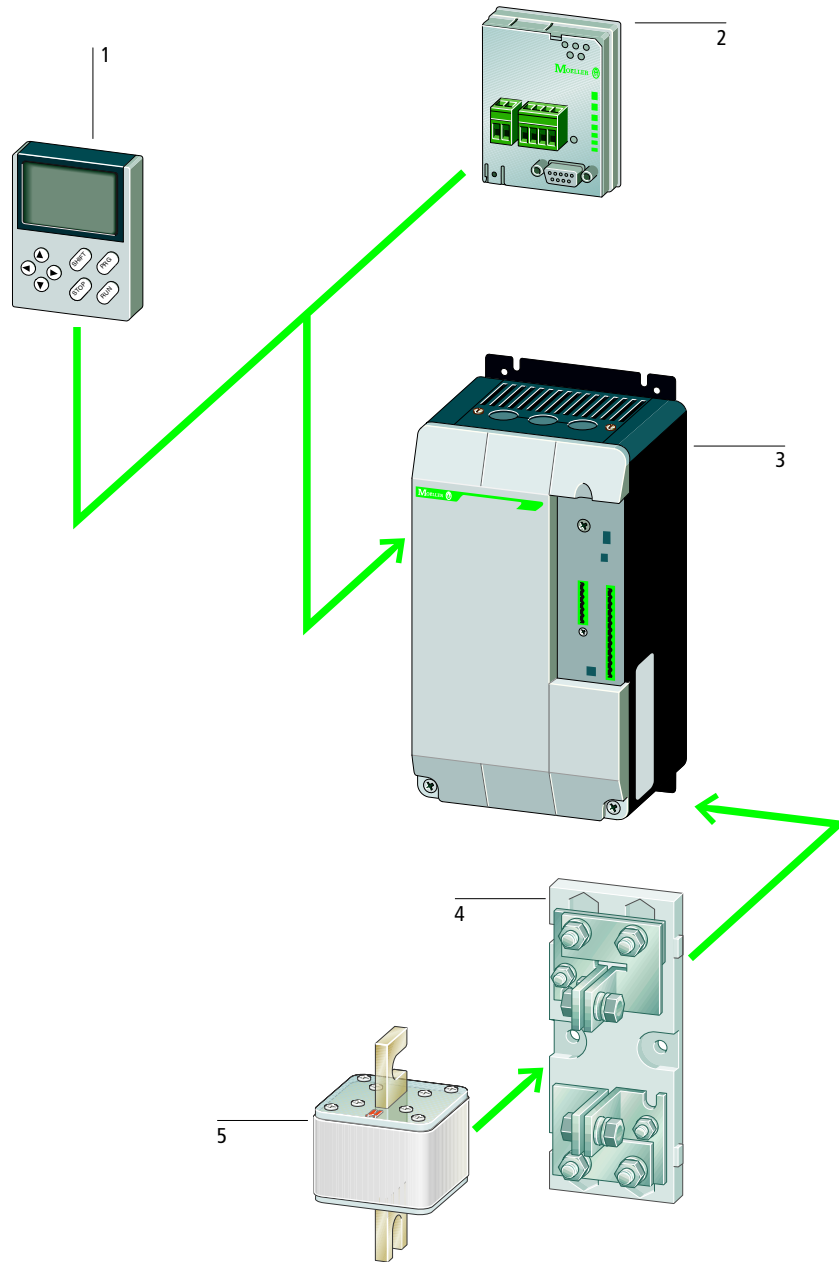

**Basic units****DM4 soft starters**

3

Motor rating from

- 7.5 to 500 kW for in-line connection (before load, standard)
- 11 to 900 kW for delta connection ( $\sqrt{3}$  circuit)

Ten configured standard applications allow immediate use.

Parameter set selection through application selector switch

Integrator time adjustable from 1 to 255 s

Energy-saving function optimizes efficiency and power factor

Adjustable current limitation prevents high starting current

Regulator operation for 3-phase resistive and inductive loads from 16 to 900 A

Selection data → Page 17/17

Ordering information → Page 17/22

**Add-on functions****DE4-KEY-2 keypad**

1

Pluggable to DM4 soft starters, with 8 function keys and plain text display; language can be selected (D/GB)

Ordering information → Page 17/22

**Communication cards**

2

DE4-COM-2X  
serial RS 485/RS 232 interfaceDE4-NET-K  
Suconet K interfaceDE4-NET-DP2  
PROFIBUS DP interface

Ordering information → Page 17/23

**Fuse base**

4

For external surface mounting of the superfast semiconductor fuse

Ordering information → Page 17/23

**Superfast semiconductor fuses**

5

Fuses for protecting semiconductors, optionally for direct flush mounting in DM4 soft starters or for external surface mounting

Selection data → Page 17/18

Ordering information → Page 17/23





### DM4 soft starters/three-phase regulators: product features

The units of the DM4 series round off the top end of Moeller's soft starter program. With a rating range starting at 7.5 kW, the DM4 soft starters are suitable for demanding automation tasks. The key features of the DM4 range are:

- Current limitation
- High overload withstand capability
- Large rating range up to 500 kW (or 900 kW in delta connection)
- Predefined parameter sets can be selected for standard applications
- All parameters also individually adjustable
- Keypad with plain text display (optional)
- Programmable relay and analog outputs
- Networkable
- Voltage regulator function (generalized phase control) can be implemented for each software changeover.

### Operation as three-phase soft starter

The DM4 series devices are soft starters for standard three-phase asynchronous motors.

**The connection type determines the rating range:**

- In-line connection (upstream of load, standard): 7.5 kW to 500 kW at 400 V
- Delta connection: 11 kW to 900 kW at 400 V, each phase of the soft starter being connected in series with the individual motor windings (6 lines required, motor delta-connected only).

### Typical applications as soft starter

- Pump drives: Soft starting prevents sudden pressure surges. The mechanical load on the entire plant is reduced and the lifespan of plant components increased.
- Fan drives and compressors: Soft starting prevents belt slippage and premature wear. This in turn lowers the operating costs and increases the lifespan of the plant.
- Conveyors: Instead of starting with a jolt, the conveyor starts up gently and the transported goods do not fall over. The mechanical stress on the conveyor is reduced and its lifespan increased.
- Circular saws, bandsaws: Current peaks are avoided due to current limitation at startup. This results in energy savings and reduced electricity bills.
- Agitators, mixers: as above.
- Mills, breakers: as above.

### Operation as three-phase regulator

The DM4 units can be changed over by software to three-phase regulator operation. The rating range is 16 A to 900 A at 400 V (standard "in-line" connection only).

They can be operated in pure regulator mode or with a closed-loop control circuit. The units each have two analog inputs for setpoint/actual values and an additional built-in current feedback loop.

A keypad or the serial interface and PC software are required to configure regulator operation.

### Typical applications as three-phase regulator

- Heater loads: Continuous temperature regulation reduces thermal and mechanical load on heating elements to increase their lifespan.
- Lighting control: Gradual switching on of lamps reduces cold-state current consumption. By using the optimum operating point of the lights, energy consumption is lowered without reducing light output, and the lifespan is increased. This results in energy savings and reduced electricity bills.
- Ozone generators: Regulation of high-voltage transformers.

### Documentation

You can download the documentation for the DM4 soft starters and the DE4-KEY-2 keypad from our website:

<http://www.moeller.net/support>  
<ftp://ftp.moeller.net/drives/index.html>



## DE4-KEY-2 keypad, RS 232C/RS 485 serial interface

Moeller HPL0211-2004/2005

**DE4-KEY-2 keypad**

The DM4 soft starters are factory-preset for the most common applications. For various standard applications, parameter sets can be selected via an application selector switch. There is no longer a need for manual setting for different applications and its associated risk of errors.

The preset application parameter sets can also be selected via an optional keypad with plain text display. With the keypad, all parameters can be viewed, edited and adapted for specific applications.

The keypad is also required for reprogramming the soft starter's digital and analog inputs and outputs. Interface modules can be used as an alternative to the keypad. The soft starters can be interfaced with a PLC via Suconet K, PROFIBUS DP or INTERBUS. Assigning parameters via the PLC offers the same range of functions as are possible via the keypad.

**Type overview****DE4-COM-2X**

RS 232C/RS 485 serial interface

**Application**

The DE4-COM-2X plug-in communication module contains RS 232C and RS 485 serial interfaces for direct connection to a PC (point-to-point connection). For use with DM4 soft starters

**Function**

The DE4-COM-2X module can be plugged in and removed during operation. It provides direct access to all parameters. The drive can be controlled and monitored from the PC. Status and alarm messages are also displayed.

**Note**

The PS416-ZBK-210 serial interface cable for connecting the serial interface with a PC must be ordered separately.

**Features**

The DE4-COM-2X module receives its power from the basic unit through the AIF slot or through two plug-in screw terminals from an external DC supply (+24 V, max. 80 mA).

RS 232C interface

- 9-pole SUB-D plug
- Pin 2 (RxD), pin 3 (TxD), pin 5 (GND)
- Point-to-point connection
- Max. cable length 15 m
- Max. baud rate 19200 bit/s

RS 485 interface

- 4-pole plug-in screw terminals
- Network topology: in-line
- Max. cable length 1200 m
- Max. baud rate 19200 bit/s

**Documentation**

For a detailed description, see manual AWB823-1279-D/GB/F.

This documentation is not supplied with the device. You can download it from our website:

- <http://www.moeller.net/support>
- <ftp://ftp.moeller.net/drives/index.html>





**Type overview**

**DE4-NET-DP2**

PROFIBUS DP fieldbus module

**Application**

The plug-in DE4-NET-DP2 communication module is used for direct connection to the PROFIBUS DP fieldbus (DIN 19245 Part 1 and 3).

For use with the following devices:

- DM4 soft starters

**Function**

The DE4-NET-DP2 module can be plugged in and removed during operation. It provides direct access to all parameters. The drive (slave) can be controlled and monitored via the PLC (master). Status and alarm messages are also displayed.

**Features**

The DE4-NET-DP2 module receives its power from the basic unit or through two plug-in screw terminals from an external DC supply (+24 V, max. 60 mA).

Design:

- 9-pole SUB-D plug
- DRIVECOM profile drive control technology 20
- Network topology: PROFIBUS DP line
- Max. cable length: 1200 m up to 93.7 Kbaud, 25 m at 12000 Kbaud

**Documentation**

For a detailed description, see the documentation:

AWB8240-1398-D (German)

This documentation is not supplied with the device. You can download it from our website:

- <http://www.moeller.net/support>
- <ftp://ftp.moeller.net/drives/index.html>

**Type overview**

**DE4-NET-K**

Suconet K fieldbus module

**Application**

The DE4-NET-K plug-in communication module enables direct connection to the Suconet K fieldbus.

For use with the following devices:

- DM4 soft starters

**Function**

The DE4-NET-K module can be plugged in and removed during operation. It provides direct access to all parameters. The drive (slave) can be controlled and monitored with the PLC (master) software. Status and alarm messages are also displayed.

**Features**

The DE4-NET-K receives its power supply from the basic unit.

Design:

- RS 485
- 3-pole plug-in connector with screw terminals: A(TA/RA), B(TB/RB), GND
- Potential isolation
- 8-pole DIP switch (addressing, bus terminating resistor)
- Network topology: in-line
- Baud rate:
  - 187.5 Kbaud at 600 m
  - 375 Kbaud at 300 m

**Documentation**

For a detailed description, see the documentation:

- AWB823-1292-D (German)
- AWB823-1292-GB (English)
- AWB823-1292-F (French)

This documentation is not supplied with the device. You can download it from our website:

- <http://www.moeller.net/support>
- <ftp://ftp.moeller.net/drives/index.html>



Moeller HPL0211-2004/2005

			DM4...
<b>Power section</b>			
Mains supply voltage	$U_L$	V	230 -10 % to 460 +10 % (45 – 65 Hz ± 0 %)
Control voltage		V AC/ DC	24 – 230
Rated operational current	$I_e$	A	16 – 900
Recommended motor rating			
In-line connection (before the load, standard)		kW	7.5 – 500 (400 V)
Delta connection (in series with each motor winding)		kW	11 – 900 (400 V)
Built-in bypass relay			–
Standards			IEC/EN 60947-4-2
Degree of protection			IP 20
Approvals			UL, cUL
Fields of application			
Fields of application			Soft starting of three-phase asynchronous motors
Single-phase loads (heaters, lamps, electroplating)			–
Three-phase loads (heaters, lamps, electroplating)			●
Three-phase motors			●
Functions			
Fast switching (semiconductor contactor)			– (minimum ramp time 1 s)
Soft start function			●
Reversing contactor function			External solution required
Suppression of closing transients			●
Current limitation			●
Overload monitoring			●
Underload monitoring			●
Analog inputs			1 × 0 – 10 V DC; 1 × 4 – 20 mA
Analog outputs			2 × 0 – 10 V DC, 10 mA
Programmable digital inputs		Number	2
Programmable relay outputs		Number	Four make contacts, of which three floating
Thermistor input			●
Fault memory		Faults	5
Preprogrammed parameter sets			Ten different standard applications: range of fans, pumps and compressors
Suppression of DC components on motors			●
Potential isolation between power section and control section			●
Interfaces (options)			PROFIBUS, Suconet K, RS 232, RS 485
<b>Notes</b>			● Included as standard







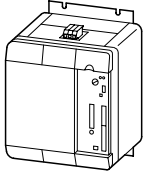
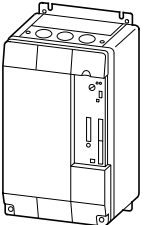
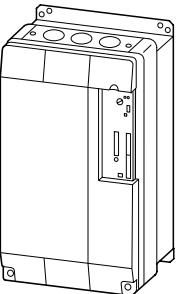
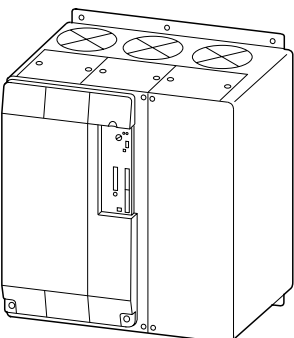
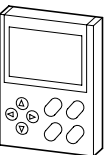

	Mains supply voltage	Rated operational current	Rated power for three-phase motors at 400 V	Type Article no.	Price See Price List	Std. pack	Notes
	$U_L$ V AC	$I_e$ A	$P$ kW				
<b>Soft starters up to 37/55 kW at 400 V</b>							
	190 – 520 V AC ± 0 %	16	7.5	<b>DM4-340-7K5</b> 207897		1 off	Specified ratings apply to in-line/delta connection
	190 – 520 V AC ± 0 %	23	11	<b>DM4-340-11K</b> 207898			
	190 – 520 V AC ± 0 %	30	15	<b>DM4-340-15K</b> 207899			
	190 – 520 V AC ± 0 %	44	22	<b>DM4-340-22K</b> 207900			
	190 – 520 V AC ± 0 %	59	30	<b>DM4-340-30K</b> 207901			
	190 – 520 V AC ± 0 %	72	37	<b>DM4-340-37K</b> 207902			
<b>Soft starters up to 75/132 kW at 400 V</b>							
	190 – 520 V AC ± 0 %	85	45	<b>DM4-340-45K</b> 207903		1 off	Specified ratings apply to in-line/delta connection
	190 – 520 V AC ± 0 %	105	55	<b>DM4-340-55K</b> 207904			
	190 – 520 V AC ± 0 %	146	75	<b>DM4-340-75K</b> 207905			
<b>Soft starters up to 200/315 kW at 400 V</b>							
	190 – 520 V AC ± 0 %	174	90	<b>DM4-340-90K</b> 207906		1 off	Specified ratings apply to in-line/delta connection
	190 – 520 V AC ± 0 %	202	110	<b>DM4-340-110K</b> 207907			
	190 – 520 V AC ± 0 %	242	132	<b>DM4-340-132K</b> 207908			
	190 – 520 V AC ± 0 %	300	160	<b>DM4-340-160K</b> 207909			
	190 – 520 V AC ± 0 %	370	200	<b>DM4-340-200K</b> 207910			
<b>Soft starters up to 500/900 kW at 400 V</b>							
	190 – 520 V AC ± 0 %	500	250	<b>DM4-340-250K</b> 207911		1 off	Specified ratings apply to in-line/delta connection
	190 – 520 V AC ± 0 %	600	315	<b>DM4-340-315K</b> 207912			
	190 – 520 V AC ± 0 %	750	400	<b>DM4-340-400K</b> 207913			
	190 – 520 V AC ± 0 %	900	500	<b>DM4-340-500K</b> 207914			
<b>Keypad</b>							
	<ul style="list-style-type: none"> <li>Allows drive control through the keypad and adaptation of all soft starter parameters for any application</li> <li>Connection to DM4 soft starters through simple plugging/pulling, also during operation</li> <li>With zero-voltage safe parameter memory. Parameter sets can be transferred between soft starters within a series</li> <li>Two-line plain text display</li> <li>Operating status signalling through status symbols</li> </ul>			<b>DE4-KEY-2</b> 211291		1 off	

Moeller HPL0211-2004/2005

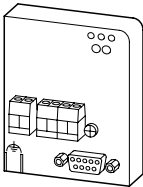
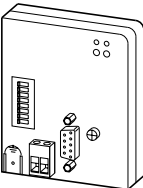
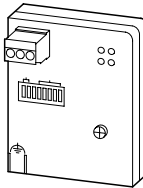
For use with	Description	Type Article no.	Price	Std. pack
<b>RS 232C/RS 485 serial interface</b>				
Module with RS 232C and RS 485 serial interfaces for direct connection to a PLC or a PC				
	DM4... soft starters	<ul style="list-style-type: none"> <li>RS 232C: 9-pin SUB-D plug</li> <li>RS 485: plug-in screw terminals</li> <li>PS416-ZBK-210 serial interface cable required</li> </ul>	DE4-COM-2X 085028	1 off
	DM4... soft starters	For connecting the programming PC through an RS 232C interface	PS416-ZBK-210 051751	1 off
<b>PROFIBUS DP communication module</b>				
Module for direct connection to the PROFIBUS DP fieldbus				
	DM4... soft starters	<ul style="list-style-type: none"> <li>All parameters can be addressed and transferred.</li> <li>Connection through 9-pin SUB-D plug</li> </ul>	DE4-NET-DP2 230240	1 off
<b>Suconet K communication module</b>				
Module for direct connection to the Suconet K fieldbus				
	DM4... soft starters	<ul style="list-style-type: none"> <li>All parameters can be addressed and transferred.</li> <li>Connection through plug-in screw terminal</li> </ul>	DE4-NET-K 085029	1 off

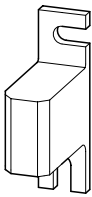
Rated current A	Max. heat dissipation $P_v$ W	Frame size/ critical dimension mm	For use with	Type Article no.	Price See Price List	Std. pack	Notes
<b>Superfast semiconductor fuses</b>							
Fuse cartridges							
	40	10	80	DM4-340-7K5	20.282.20-40 232085	6 off	–
	80	18	80	DM4-340-11K DM4-340-15K	20.282.20-80 232086		–
	125	26	80	DM4-340-22K DM4-340-30K	20.282.20-125 232087		–
	200	37	80	DM4-340-37K DM4-340-45K	20.189.20-200 232088	3 off	–
	350	61	80	DM4-340-55K DM4-340-75K	20.610.32-350 221161	2 off	Mounted internally
	450	70	80	DM4-340-90K DM4-340-110K	20.610.32-450 221162		
	500	72	80	DM4-340-132K DM4-340-160K	20.610.32-500 221163		
	630	80	80	DM4-340-200K	20.610.32-630 221164	3 off	
	900	120	80	DM4-340-250K DM4-340-315K	20.630.32-900 221165	2 off	
	1250	147	80	DM4-340-400K DM4-340-500K	20.630.32-1250 221166	2 off	
Fuse base for external surface mounting of semiconductor fuses							
–	–	80	20.282.20-... 20.189.20-...	21.189.01 232064		5 off	–
–	–	80	20.6xx.32-...	21.313.02 232076		2 off	For semiconductor fuses 20.6xx.32-...

DM4 soft starters



Immediate blocking without ramp function

Actuation

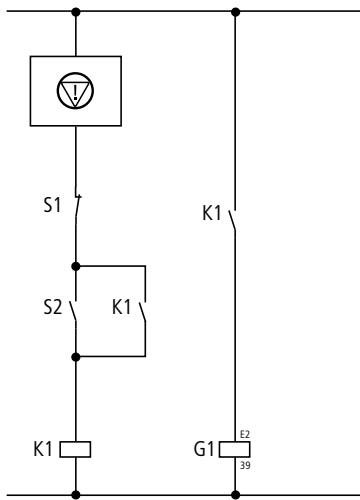

For this function, the illustrated circuit must be added to all of the following circuit examples.  
The required parameter settings for input E2 are described in the manual.

-  Emergency-Stop
- S1: Off
- S2: On
- G1: Enable (E2 = 1 → enabled)

Inclusion of the Z relay

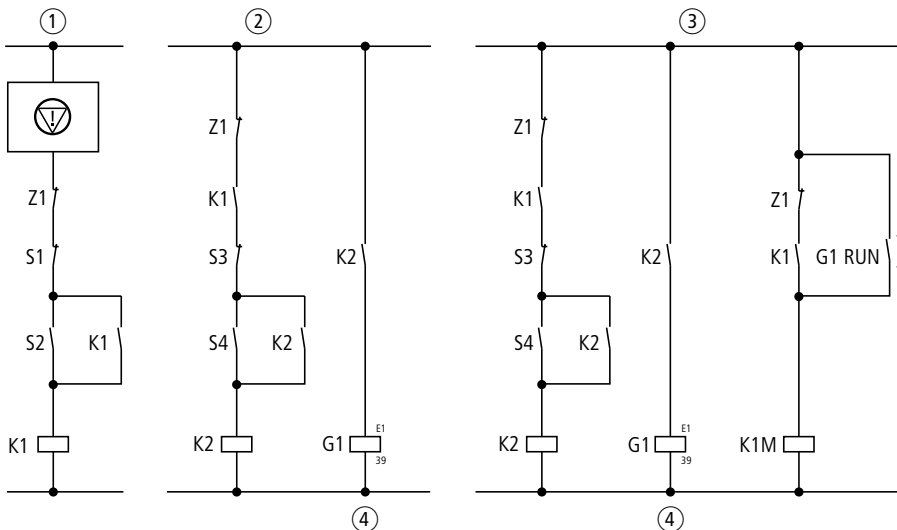

 Emergency-Stop

- S1: Off
- S2: On
- G1: Enable (E2 = 1 → enabled)

- ① The overload relay's signal contacts are included in the On/Off circuit. In the event of a fault, the soft starter is immediately locked and the motor coasts to a halt. Mains contactor K1M drops out as soon as the Run relay drops out.
- ② The overload relay's signal contacts are included in the soft start/stop circuit. In the event of a fault, the soft starter is ramped down. The soft starter switches off but the mains contactor remains active.
- ③ To switch the mains contactor as well, a second contact of the overload relay must be connected into the branch of the K1M mains contactor in addition to version 2. After completion of the soft stop, the Run relay drops out, thereby cancelling the holding circuit of the K1M.
- ④ Soft stop  
Soft start

Wiring

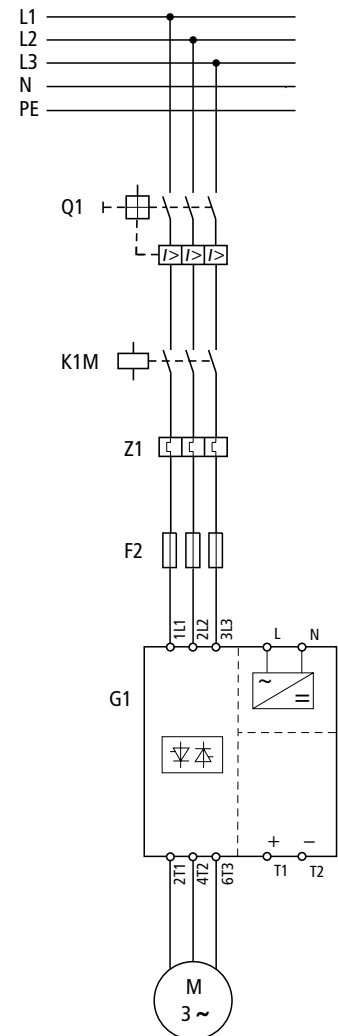

T1, T2: Thermistor

Moeller HPL0211-2004/2005

Soft starter with mains contactor (K1M)

Actuation

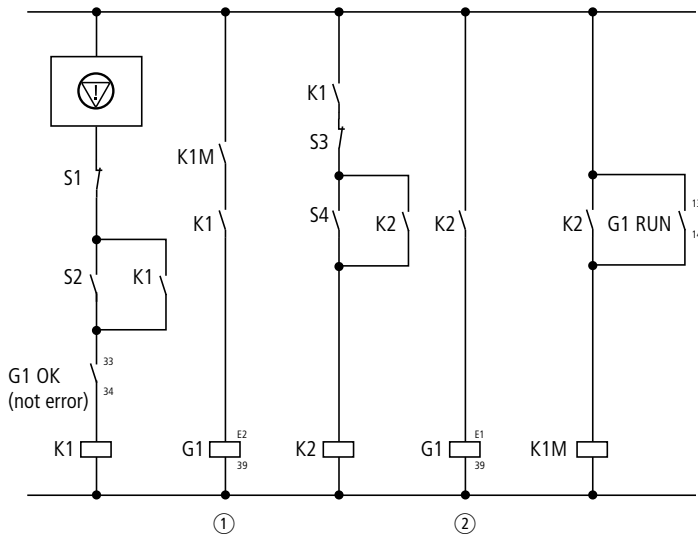

Emergency-Stop

- S1: Off
- S2: On
- S3: Soft stop
- S4: Soft start
- ①: Enable
- ②: Soft stop  
Soft start

Wiring

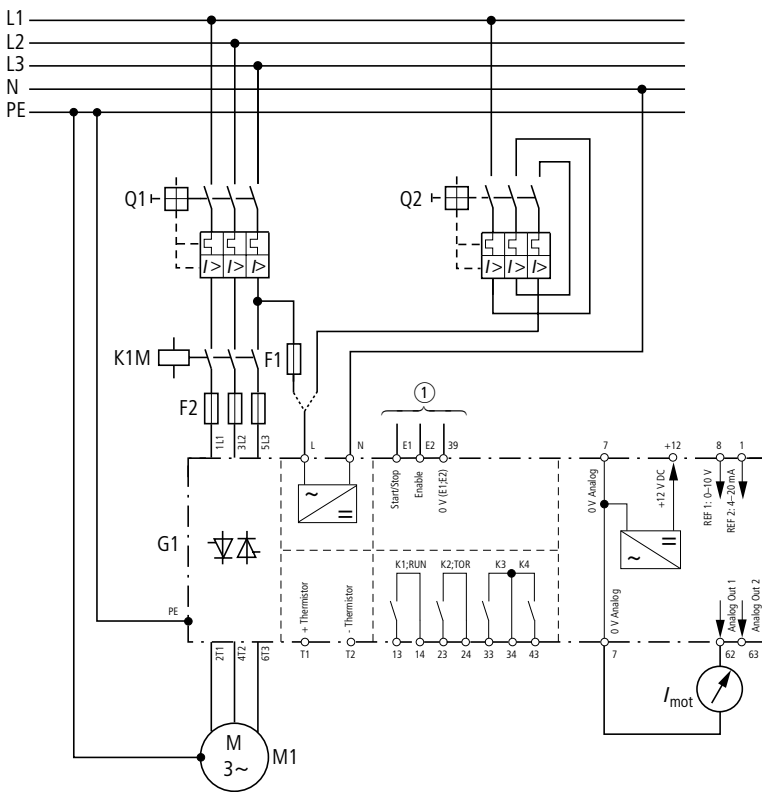



①: See actuation

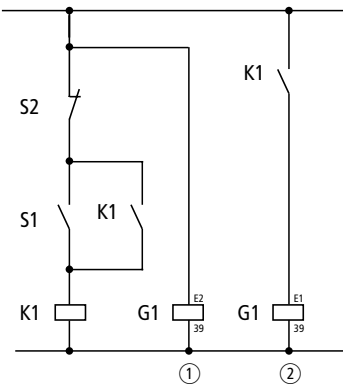

## Soft starter without separate mains contactor (K1M)

Actuation



-  Emergency-Stop
- S1: Soft stop
- S2: Soft start
- ①: Enable
- ②: Soft stop
- ②: Soft start

Wiring

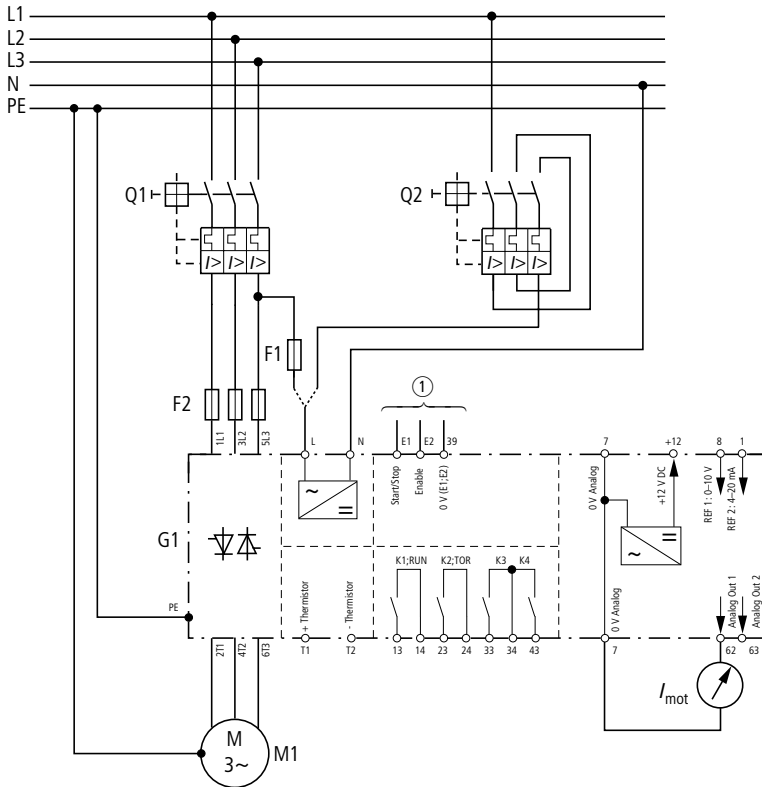

①: See actuation



Moeller HPL0211-2004/2005

Soft starter with bypass and mains contactor (K1M)

Actuation

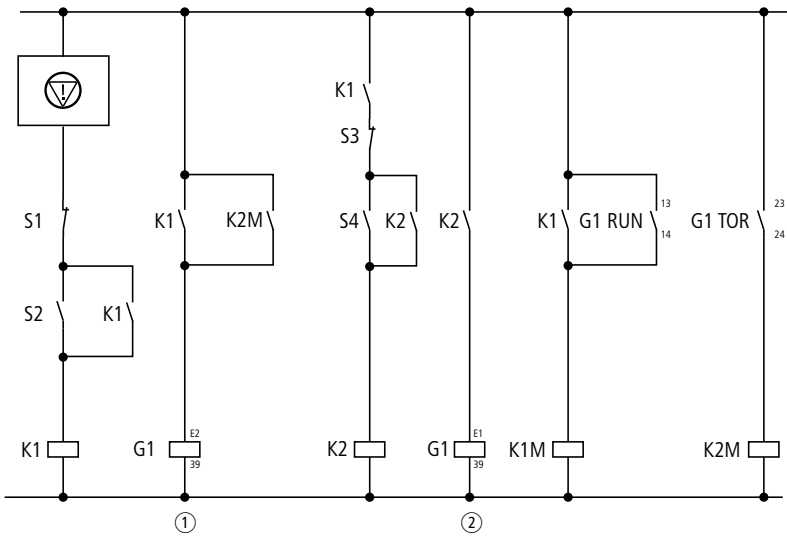

-  Emergency-Stop
- S1: Off
- S2: On
- S3: Soft stop
- S4: Soft start
- ①: Enable
- ②: Soft stop  
Soft start

Wiring

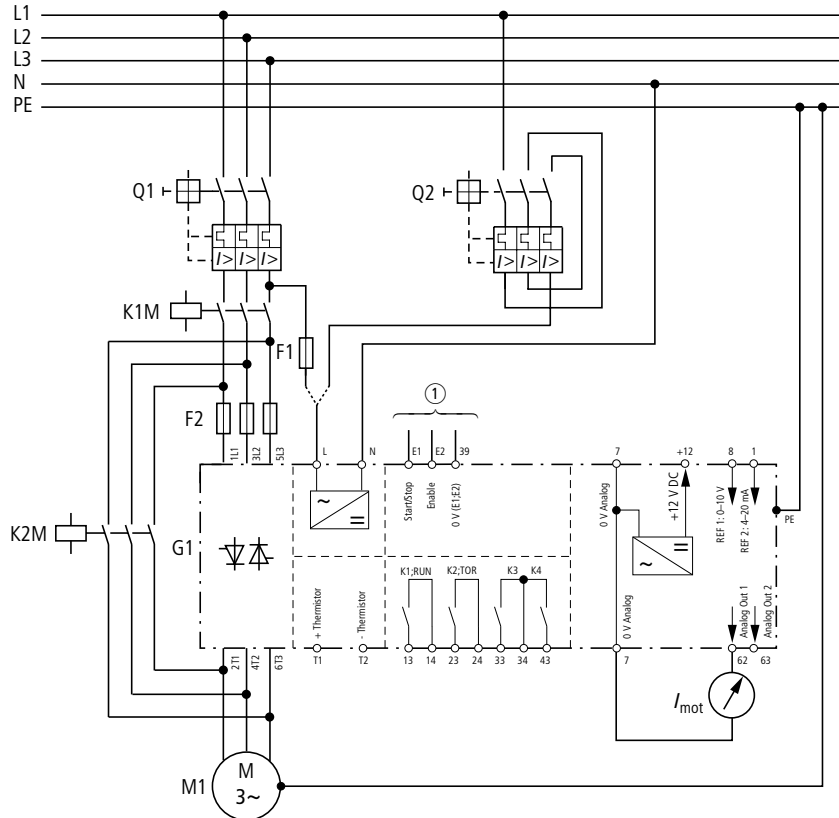

①: See actuation





Soft starter with mains contactor (K1M),  
delta connection

Actuation

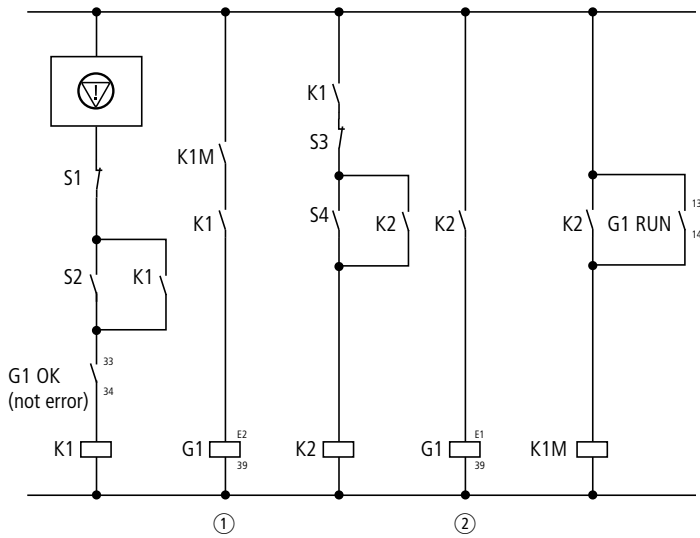

- Emergency-Stop
- S1: Off
- S2: On
- S3: Soft stop
- S4: Soft start
- ①: Enable
- ②: Soft stop  
Soft start

Wiring

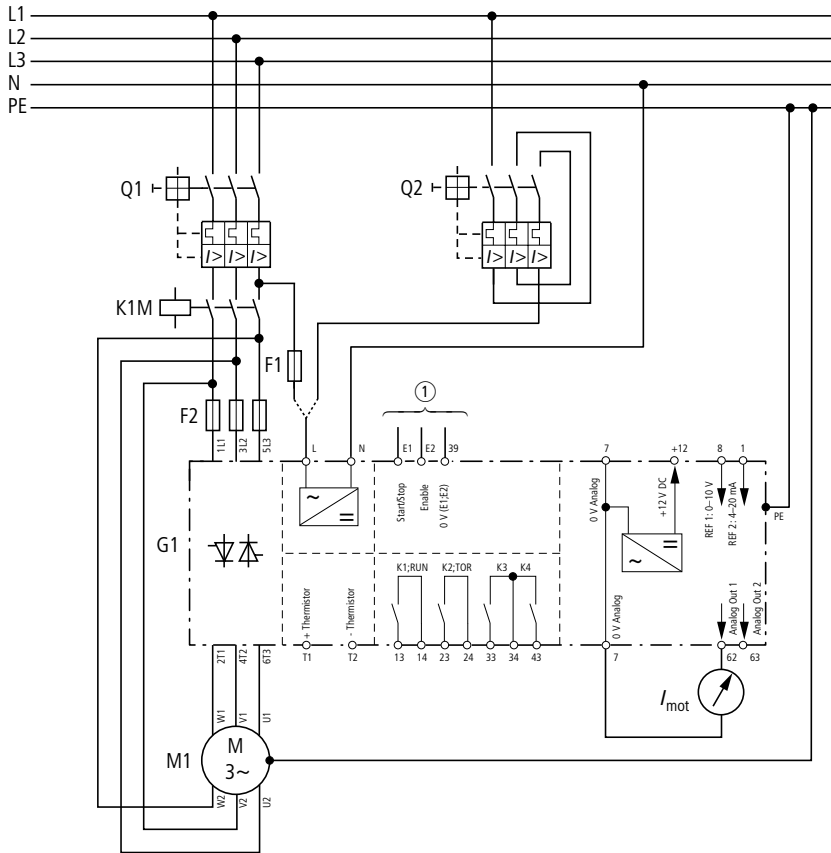

- ①: See actuation

Moeller HPL0211-2004/2005

Soft starter with reversing circuit

Actuation

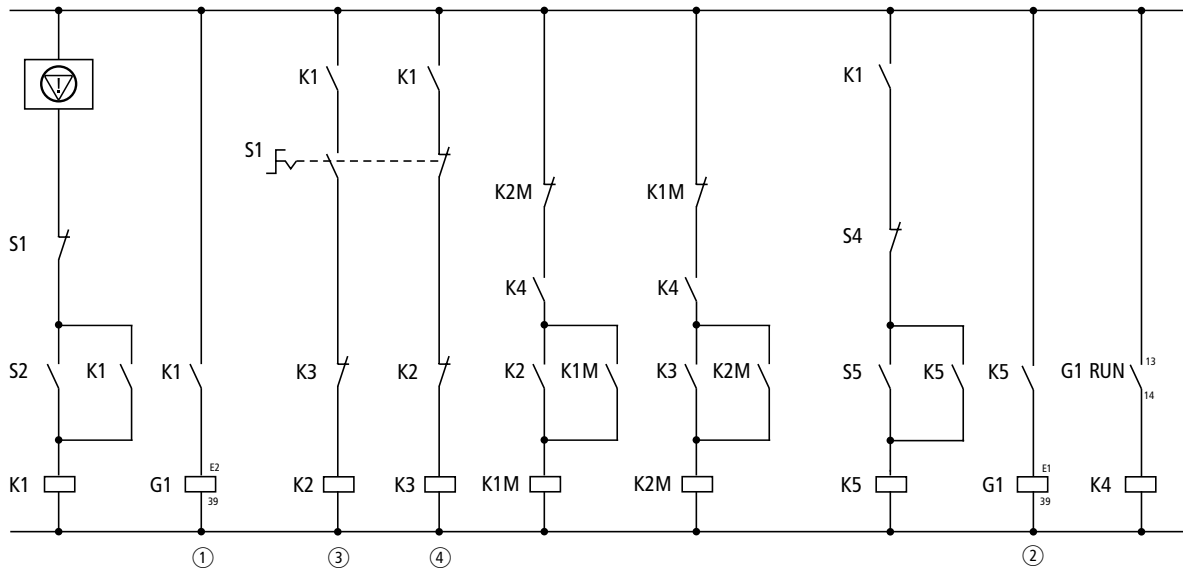

Emergency-Stop

- |                |              |
|----------------|--------------|
| S1: Off        | ①: Enable    |
| S2: On         | ②: Soft stop |
| S4: Soft stop  | ③: Forwards  |
| S5: Soft start | ④: Reverse   |

Wiring

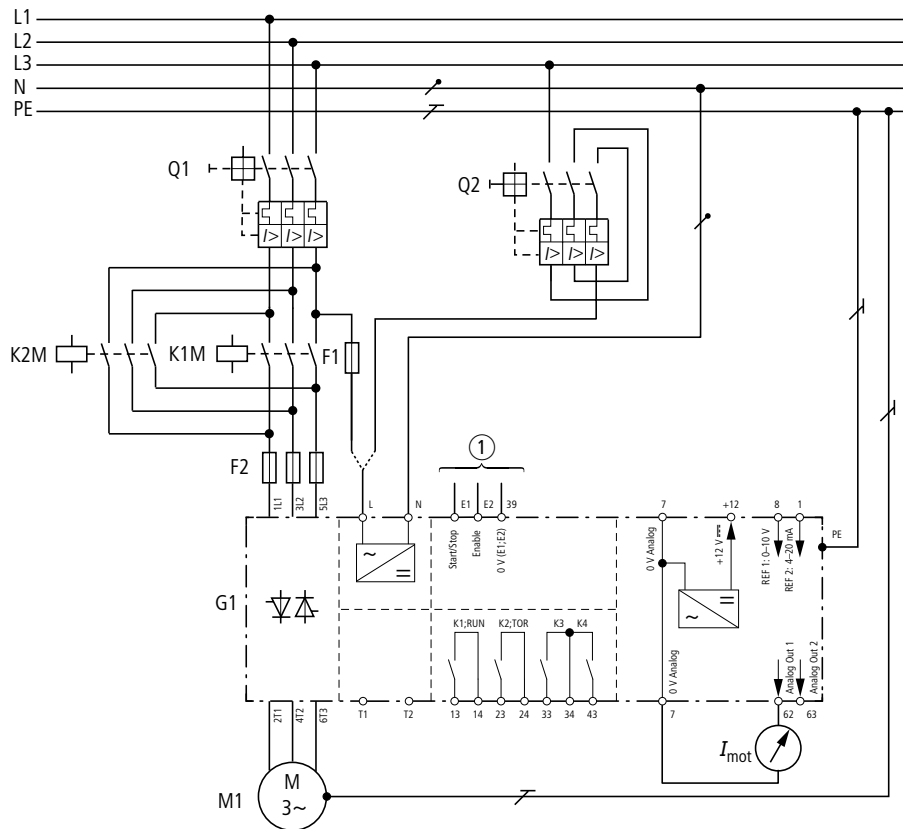

①: See actuation



# 17/30 Technical data

## DS4 semiconductor contactors and soft starters

Moeller HPL0211-2004/32005

			DS4-140-010-H	DS4-140-020-H	DS4-140-030-H	DS4-140-050-H
<b>General</b>						
Standards			IEC/EN 60947-4-3	IEC/EN 60947-4-3	IEC/EN 60947-4-3	IEC/EN 60947-4-3
Approvals			UL/CSA	UL/CSA	UL/CSA	UL/CSA
Climatic proofing			Damp heat, constant according to IEC 60068-2-78; damp heat, cyclical, according to IEC 60068-2-10			
Ambient temperature		°C	0 – 40	0 – 40	0 – 40	0 – 40
Ambient temperature for storage		°C	25/55	25/55	25/55	25/55
Altitude		m	0 – 1000	0 – 1000	0 – 1000	0 – 1000
Mounting position			Vertical	Vertical	Vertical	Vertical
Degree of protection			IP 20	IP 20	IP 20	IP 20
Contact protection			Finger- and back-of-hand proof			
Overvoltage category/pollution degree			II/2	II/2	II/2	II/2
Mechanical shock resistance			10 g/11 ms	10 g/11 ms	10 g/11 ms	10 g/11 ms
Vibration resistance to EN 60721-3-2		g	2M2	2M2	2M2	2M2
Heat dissipation at rated operational current $I_e$		W	12	24	36	60
Dimensions (w × h × d)		mm	45 × 149 × 189.5	45 × 149 × 189.5	45 × 149 × 189.5	65 × 149 × 189.5
Radio interference level			"A"	"A"	"A"	"A"
<b>Main contacts</b>						
Rated operational voltage	$U_e$	V AC	110 – 500	110 – 500	110 – 500	110 – 500
Supply frequency		Hz	50/60	50/60	50/60	50/60
Rated operational current						
AC-51 (resistive load)	$I_e$	A	10	20	30	50
Overload cycle			Operating frequency limited only by the mains frequency and make/break times; $1 \times I_N$			
<b>Terminal capacities</b>						
<b>Power cables</b>						
Solid		mm <sup>2</sup>	1 × (1.5 – 6) 2 × (1.5 – 4)	1 × (1.5 – 6) 2 × (1.5 – 4)	1 × (1.5 – 6) 2 × (1.5 – 4)	1 × (1.5 – 35) 2 × (1.5 – 10)
Flexible with ferrule		mm <sup>2</sup>	1 × (1.5 – 6) 2 × (1.5 – 4)	1 × (1.5 – 6) 2 × (1.5 – 4)	1 × (1.5 – 6) 2 × (1.5 – 4)	1 × (1.5 – 25) 2 × (1.5 – 2.5)
Stranded		mm <sup>2</sup>	1 × (1.5 – 6) 2 × (1.5 – 4)	1 × (1.5 – 6) 2 × (1.5 – 4)	1 × (1.5 – 6) 2 × (1.5 – 4)	1 × (1.5 – 35) 2 × (1.5 – 10)
Solid or stranded		AWG	1 × (16 – 8) 2 × (16 – 10)	1 × (16 – 8) 2 × (16 – 10)	1 × (16 – 8) 2 × (16 – 10)	1 × (16 – 4) 2 × (16 – 12)
Tightening torque		Nm	1.7	1.7	1.7	3
Screwdriver (PZ: Pozidriv)		mm	PZ2 or 1 × 6 mm	PZ2 or 1 × 6 mm	PZ2 or 1 × 6 mm	PZ2 or 1 × 6 mm
<b>Control cables</b>						
Solid		mm <sup>2</sup>	1 × (0.75 – 2.5) 2 × (0.75 – 1.5)	1 × (0.75 – 2.5) 2 × (0.75 – 1.5)	1 × (0.75 – 2.5) 2 × (0.75 – 1.5)	1 × (0.75 – 2.5) 2 × (0.75 – 1.5)
Flexible with ferrule		mm <sup>2</sup>	1 × (0.75 – 2.5) 2 × 0.75	1 × (0.75 – 2.5) 2 × 0.75	1 × (0.75 – 2.5) 2 × 0.75	1 × (0.75 – 2.5) 2 × 0.75
Stranded		mm <sup>2</sup>	1 × (0.75 – 2.5) 2 × (0.75 – 1.5)	1 × (0.75 – 2.5) 2 × (0.75 – 1.5)	1 × (0.75 – 2.5) 2 × (0.75 – 1.5)	1 × (0.75 – 2.5) 2 × (0.75 – 1.5)
Solid or stranded		AWG	18 – 12	18 – 12	18 – 12	18 – 12
Tightening torque		Nm	0.8	0.8	0.8	0.8
Screwdriver		mm	0.5 × 3.5	0.5 × 3.5	0.5 × 3.5	0.5 × 3.5

### Notes

- Rated impulse withstand voltage
- 1.2 μs/50 μs (pulse rise/fall time to IEC/EN 60947-2 or -3)
  - Applies for control circuit/power section/enclosure



DS4 semiconductor contactors and soft starters

Moeller HPL0211-2004/32005

			DS4-140-010-H	DS4-140-020-H	DS4-140-030-H	DS4-140-050-H
<b>Power section</b>						
Rated impulse withstand voltage	$U_{imp}$	kV	6	6	6	6
Rated insulation voltage	$U_i$	V AC	500	500	500	500
Rated operational voltage	$U_e$	V	500	500	500	500
<b>Short-circuit rating</b>						
Type "1" coordination						
	At 230 V		FAZ-B10/1	FAZ-B20/1	FAZ-B32/1	FAZ-B50/1
	At 400 V		10 A gL or 2 × FAZ-B10/1	20 A gL or 2 × FAZ-B20/1	35 A gL or 2 × FAZ-B32/1	50 A gL or 2 × FAZ-B50/1
	At 500 V		PKM0-10 + Z00-10	PKM0-20 (+ CL-PKZ0) + Z00-24 (+ EZ00)	PKZ2 + M-32-PKZ2 (+ CL-PKZ2) + Z1-40 (+ EZ1)	NZM7-63-OBI + Z1-63 (+ EZ1)
Short-circuit rating type "2" coordination (in addition to the fuses for type "1" coordination)						
			50.179.06-16	50.124.06-32	50.140.06-50	50.140.06-80
	Fuse holders		51.063.04	51.058.04	51.060.04	51.060.04
<b>Control circuit</b>						
Current consumption						
Minimum control voltage		V AC / DC	110 / 24	110 / 24	110 / 24	110 / 24
Digital inputs						
	24 V DC	mA	12	12	12	12
	230 V AC	mA	12	12	12	12
Control section power supply $U_c$		V AC	Not applicable	Not applicable	Not applicable	Not applicable
Control voltage						
DC operated		V DC	+24 ±15%	+24 ±15%	+24 ±15%	+24 ±15%
AC-operated		V AC	110 – 240 ±15%	110 – 240 ±15%	110 – 240 ±15%	110 – 240 ±15%
Pick-up voltage						
DC operated		V DC	15 – 27	15 – 27	15 – 27	15 – 27
AC-operated		V AC	79 – 264	79 – 264	79 – 264	79 – 264
Drop-out voltage						
DC operated		V DC	0 – 3	0 – 3	0 – 3	0 – 3
AC-operated		V AC	0 – 18	0 – 18	0 – 18	0 – 18
Pick-up time						
DC operated		ms	10	10	10	10
AC-operated		ms	10	10	10	10
Drop-out time						
DC operated		ms	20	20	20	20
AC-operated		ms	25	25	25	25

Notes

- Rated impulse withstand voltage
- 1.2 μs/50 μs (pulse rise/fall time to IEC/EN 60947-2 or -3)
  - Applies for control circuit/power section/enclosure



Moeller HPL0211-2004/2005

			DS4-340-2K2-M(R)	DS4-340-2K2-M(R)-DC
<b>General</b>				
Standards			IEC/EN 60947-4-2 (-M(R)) IEC/EN 60947-4-3 (-M)	
Approvals			UL/CSA	UL/CSA
Climatic proofing			Damp heat, constant, to IEC 60068-2-78 Damp heat, cyclic, to IEC 60068-2-10	
Ambient temperature	°C		0 – 40	0 – 40
Ambient temperature for storage	°C		25/55	25/55
Altitude	m		0 – 1000	0 – 1000
Mounting position			Vertical	Vertical
Degree of protection (power terminals)			IP 20	IP 20
Contact protection			Finger- and back-of-hand proof	
Overvoltage category/pollution degree			II/2	II/2
Mechanical shock resistance			8 g/11 ms	8 g/11 ms
For AC-51: 1.5-1: 600-99	g		2M2	2M2
Heat dissipation at rated operational current $I_e$	W		23.4	23.4
Dimensions (w × h × d)	mm		45 × 149 × 189.5	45 × 149 × 189.5
Radio interference level			"A"	"A"
<b>Main contacts</b>				
Rated operational voltage	$U_e$	V AC	110 – 500	110 – 500
Supply frequency		Hz	50/60	50/60
Control section power supply $U_c$		V AC	Internal through power terminal	
Rated operational current				
AC-51	$I_e$	A	11	11
AC-53 (inductive load)	$I_e$	A	6	6
Assigned motor rating (standard connection)				
230 V		kW	1.1	1.1
400 V		kW	2.2	2.2
460 V		HP	3	3
500 V		kW	3	3
Overload cycle to IEC/EN 60947-4-2				
AC-51 (only for M types)			11 A: AC-51: 1.5 – 1: 99 – 600	11 A: AC-51: 1.5 – 1: 99 – 600
AC-53a (without bypass)			6 A: AC-53a: 6 – 0.5: 99 – 600 6 A: AC-53a: 6 – 5: 99 – 20	6 A: AC-53a: 6 – 0.5: 99 – 600 6 A: AC-53a: 6 – 5: 99 – 20
<b>Terminal capacities</b>				
Power cables				
Solid		mm <sup>2</sup>	1 × (1.5 – 6) 2 × (1.5 – 4)	1 × (1.5 – 6) 2 × (1.5 – 4)
Flexible with ferrule		mm <sup>2</sup>	1 × (1.5 – 6) 2 × (1.5 – 4)	1 × (1.5 – 6) 2 × (1.5 – 4)
Stranded		mm <sup>2</sup>	1 × (1.5 – 6) 2 × (1.5 – 4)	1 × (1.5 – 6) 2 × (1.5 – 4)
Solid or stranded		AWG	1 × (16 – 8) 2 × (16 – 10)	1 × (16 – 8) 2 × (16 – 10)
Tightening torque		Nm	1.7	1.7
Screwdriver (PZ: Pozidriv)		mm	PZ2 or 1 × 6 mm	PZ2 or 1 × 6 mm
Control cables				
Solid		mm <sup>2</sup>	1 × (0.75 – 2.5) 2 × (0.75 – 1.5)	1 × (0.75 – 2.5) 2 × (0.75 – 1.5)
Flexible with ferrule		mm <sup>2</sup>	1 × (0.75 – 2.5) 2 × (0.75 – 1.5)	1 × (0.75 – 2.5) 2 × (0.75 – 1.5)
Stranded		mm <sup>2</sup>	1 × (0.75 – 2.5) 2 × (0.75 – 1.5)	1 × (0.75 – 2.5) 2 × (0.75 – 1.5)
Solid or stranded		AWG	1 × (18 – 12) 2 × (18 – 16)	1 × (18 – 12) 2 × (18 – 16)
Tightening torque		Nm	0.8	0.8
Screwdriver		mm	0.5 × 3.5	0.5 × 3.5

Notes

- Rated impulse withstand voltage:  
 • 1.2 μs/50 μs (pulse rise/fall time to IEC/EN 60947-2 or -3)  
 • Applies for control circuit/power section/enclosure

Moeller HPL0211-2004/2005

DS4-340-4K0-M(R)	DS4-340-5K5-M(R)	DS4-340-7K5-M(R)	DS4-340-11K-M(R)	DS4-340-11K-M + DIL2M(230V50HZ)
IEC/EN 60947-4-2 (-M(R)) IEC/EN 60947-4-3 (-M)				
UL/CSA	UL/CSA	UL/CSA	UL/CSA	UL/CSA
Damp heat, constant according to IEC 60068-2-78; damp heat, cyclical, according to IEC 60068-2-10				
0 – 40	0 – 40	0 – 40	0 – 40	0 – 40
25/55	25/55	25/55	25/55	25/55
0 – 1000	0 – 1000	0 – 1000	0 – 1000	0 – 1000
Vertical	Vertical	Vertical	Vertical	Vertical
IP 20 (IP 00)	IP 20 (IP 00)	IP 20 (IP 00)	IP 20 (IP 00)	IP 20
Finger- and back-of-hand proof				
II/2	II/2	II/2	II/2	II/2
8 g/11 ms	8 g/11 ms	8 g/11 ms	8 g/11 ms	8 g/11 ms
2M2	2M2	2M2	2M2	2M2
43.8	57.4	57.4	81.2	85.8
65 × 149 × 189.5	65 × 149 × 189.5	110 × 149 × 189.5	110 × 149 × 189.5	45 × 149 × 189.5
"A"	"A"	"A"	"A"	"A"
110 – 500	110 – 500	110 – 500	110 – 500	110 – 500
50/60	50/60	50/60	50/60	50/60
Internal through power terminal				
17	22	29	41	41
9	12	16	23	23
2.2	3	4	5.5	11
4	5.5	7.5	11	22
5	7	10	15	30
5.5	5.5	7.5	11	30
17 A: AC-51: 1.5 – 1: 99 – 600	22 A: AC-51: 1.5 – 1: 99 – 600	29 A: AC-51: 1.5 – 1: 99 – 600	41 A: AC-51: 1.5 – 1: 99 – 600	–
9 A: AC-53a: 6 – 0.5: 99 – 600 9 A: AC-53a: 6 – 5: 99 – 20	12 A: AC-53a: 6 – 0.5: 99 – 600 12 A: AC-53a: 6 – 5: 99 – 20	16 A: AC-53a: 6 – 0.5: 99 – 600 16 A: AC-53a: 6 – 5: 99 – 20	23 A: AC-53a: 6 – 0.5: 99 – 600 23 A: AC-53a: 6 – 5: 99 – 20 41 A: AC-53b: 3 – 5: 360 (-M only)	23 A: AC-53a: 6 – 0.5: 99 – 600 23 A: AC-53a: 6 – 5: 99 – 20 41 A: AC-53b: 3 – 5: 360 (-M only)
1 × (1.5 – 35) 2 × (1.5 – 10)	1 × (1.5 – 35) 2 × (1.5 – 10)	1 × (2.5 – 50) 2 × (2.5 – 16)	2 × (2.5 – 50) 3 × (2.5 – 16)	2 × (2.5 – 50) 3 × (2.5 – 16)
1 × (1.5 – 25) 2 × (1.5 – 6)	1 × (1.5 – 25) 2 × (1.5 – 6)	1 × (2.5 – 35) 2 × (2.5 – 10)	2 × (2.5 – 35) 3 × (2.5 – 10)	2 × (2.5 – 35) 3 × (2.5 – 10)
1 × (1.5 – 35) 2 × (1.5 – 10)	1 × (1.5 – 35) 2 × (1.5 – 10)	1 × (2.5 – 50) 2 × (2.5 – 16)	2 × (2.5 – 50) 3 × (2.5 – 16)	2 × (2.5 – 50) 3 × (2.5 – 16)
1 × (16 – 4) 2 × (16 – 10)	1 × (16 – 4) 2 × (16 – 10)	1 × (14 – 2) 2 × (14 – 8)	2 × (14 – 2) 3 × (14 – 8)	2 × (14 – 2) 3 × (14 – 8)
3	3	3.5	3.5	3.5
PZ2 or 1 × 6 mm	PZ2 or 1 × 6 mm	PZ2 or 1 × 6 mm	PZ2 or 1 × 6 mm	PZ2 or 1 × 6 mm
1 × (0.75 – 2.5) 2 × (0.75 – 1.5)	1 × (0.75 – 2.5) 2 × (0.75 – 1.5)	1 × (0.75 – 2.5) 2 × (0.75 – 1.5)	1 × (0.75 – 2.5) 2 × (0.75 – 1.5)	1 × (0.75 – 2.5) 2 × (0.75 – 1.5)
1 × (0.75 – 2.5) 2 × (0.75 – 1.5)	1 × (0.75 – 2.5) 2 × (0.75 – 1.5)	1 × (0.75 – 2.5) 2 × (0.75 – 1.5)	1 × (0.75 – 2.5) 2 × (0.75 – 1.5)	1 × (0.75 – 2.5) 2 × (0.75 – 1.5)
1 × (0.75 – 2.5) 2 × (0.75 – 1.5)	1 × (0.75 – 2.5) 2 × (0.75 – 1.5)	1 × (0.75 – 2.5) 2 × (0.75 – 1.5)	1 × (0.75 – 2.5) 2 × (0.75 – 1.5)	1 × (0.75 – 2.5) 2 × (0.75 – 1.5)
1 × (18 – 12) 2 × (18 – 16)	1 × (18 – 12) 2 × (18 – 16)	1 × (18 – 12) 2 × (18 – 16)	1 × (18 – 12) 2 × (18 – 16)	1 × (18 – 12) 2 × (18 – 16)
0.8	0.8	0.8	0.8	0.8
0.5 × 3.5	0.5 × 3.5	0.5 × 3.5	0.5 × 3.5	0.5 × 3.5



Moeller HPL0211-2004/2005

			DS4-340-2K2-M(R)	DS4-340-2K2-M(R)-DC
<b>Power section</b>				
Rated impulse withstand voltage	$U_{imp}$	kV	6	6
Rated insulation voltage	$U_i$	V AC	500	500
Short-circuit rating				
Type "1" coordination				
			PKM0-16 (+ CL-PKZ0)	PKM0-16 (+ CL-PKZ0)
			PKM0-6,3 (+ CL-PKZ0) + Z00-6 (+ EZ00)	PKM0-6,3 (+ CL-PKZ0) + Z00-6 (+ EZ00)
			PKM0-10 (+ CL-PKZ0) + ZEV + ZEV-XSW-25	PKM0-10 (+ CL-PKZ0) + ZEV + ZEV-XSW-25
Short-circuit rating type "2" coordination (in addition to the fuses for type "1" coordination)			3 × 50.140.06-50	3 × 50.140.06-50
Fuse holders			3 × 51.060.04	3 × 51.060.04
<b>Control circuit</b>				
Current consumption				
Minimum control voltage		V AC / DC	110 / 24	24
Digital inputs				
	24 V DC	mA	14	14
	230 V AC	mA	14	14
Control section power supply $U_c$		V AC	Internal through power terminal	
Control voltage				
DC operated		V DC	+24 ±15%	+24 ±15%
AC-operated		V AC	110 – 240 ±15%	–
Pick-up voltage				
DC operated		V DC	15 – 27	15 – 27
AC-operated		V AC	79 – 264	–
Drop-out voltage				
DC operated		V DC	0 – 3	0 – 3
AC-operated		V AC	0 – 22	–
Pick-up time				
DC operated		ms	95	45
AC-operated		ms	115	–
Drop-out time				
DC operated		ms	165	–
AC-operated		ms	165	45
Relay outputs				
Quantity			1	1
Voltage range		V AC	250	250
Current range, AC-1		A	3	3
<b>Soft start function</b>				
Ramp times				
Acceleration time		s	0 – 10	0 – 10
Delay time		s	0 – 10	0 – 10
Start pedestal		%	30 – 100	30 – 100

Notes

- Rated impulse withstand voltage:
- 1.2 μs/50 μs (pulse rise/fall time to IEC/EN 60947-2 or -3)
  - Applies for control circuit/power section/enclosure

Moeller HPL0211-2004/2005

DS4-340-4K0-M(R)	DS4-340-5K5-M(R)	DS4-340-7K5-M(R)	DS4-340-11K-M(R)	DS4-340-11K-M + DIL2M(230V50HZ)
6	6	6	6	6
500	500	500	500	500
PKM0-20 (+ CL-PKZ0)	PKM0-25 (+ CL-PKZ0)	PKM4-32	PKM4-50	–
PKM0-10 (+ CL-PKZ0) + Z00-10 (+ EZ00)	PKM0-16 (+ CL-PKZ0) + Z00-16 (+ EZ00)	PKM0-16 (+ CL-PKZ0) + Z00-16 (+ EZ00)	PKM0-25 (+ CL-PKZ0) + Z00-24 (+ EZ00)	AC-53b only NZM7-63N-OBI + Z1-57 (+EZ1)
PKM0-20 (+ CL-PKZ0) + ZEV + ZEV-XSW-25	PKM0-25 (+ CL-PKZ0) + ZEV + ZEV-XSW-25	NZM7-40N-OBI + ZEV + ZEV-XSW-25	NZM7-63N-OBI + ZEV + ZEV-XSW-25	–
3 × 50.140.06-63	3 × 50.140.06-80	3 × 50.140.06-125	3 × 50.140.06-160	3 × 20.282.20-200
3 × 51.060.04	3 × 51.060.04	3 × 21.189.01	3 × 21.189.01	3 × 21.189.01
110 / 24	110 / 24	110 / 24	110 / 24	110 / 24
14	14	14	14	14
14	14	14	14	14
Internal through power terminal				
+24 ±15%	+24 ±15%	+24 ±15%	+24 ±15%	+24 ±15%
110 – 240 ±15%	110 – 240 ±15%	110 – 240 ±15%	110 – 240 ±15%	110 – 240 ±15%
15 – 27	15 – 27	15 – 27	15 – 27	15 – 27
79 – 264	79 – 264	79 – 264	79 – 264	79 – 264
0 – 3	0 – 3	0 – 3	0 – 3	0 – 3
0 – 22	0 – 22	0 – 22	0 – 22	0 – 22
95	95	95	95	95
115	115	115	115	115
165	165	165	165	165
165	165	165	165	165
1	1	1	1	1
250	250	250	250	250
3	3	3	3	3
0 – 10	0 – 10	0 – 10	0 – 10	0 – 10
0 – 10	0 – 10	0 – 10	0 – 10	0 – 10
30 – 100	30 – 100	30 – 100	30 – 100	30 – 100



# 17/36 Technical data

## DS4 semiconductor contactors and soft starters

Moeller HPL0211-2004/32005

			DS4-340-7K5-MX(R)	DS4-340-11K-MX(R)	DS4-340-15K-MX(R)
<b>General</b>					
Standards			IEC/EN 60947-4-2		
Approvals			UL/CSA	UL/CSA	UL/CSA
Climatic proofing			Damp heat, constant according to IEC 60068-2-78; damp heat, cyclical, according to IEC 60068-2-10		
Ambient temperature		°C	0 – 40	0 – 40	0 – 40
Ambient temperature for storage		°C	25/55	25/55	25/55
Altitude		m	0 – 1000	0 – 1000	0 – 1000
Mounting position			Vertical	Vertical	Vertical
Degree of protection (power terminals)			IP 20	IP 20	IP 20 (IP 00)
Contact protection			Finger- and back-of-hand proof		
Overvoltage category/pollution degree			II/2	II/2	II/2
Mechanical shock resistance			8 g/11 ms	8 g/11 ms	8 g/11 ms
Dimensions (w × h × d)		mm	45 × 149 × 189.5	45 × 149 × 189.5	110 × 149 × 189.5
Radio interference level			"A"	"A"	"A"
Power loss		W	11.2	11.9	12.7
<b>Main contacts</b>					
Rated operational voltage	$U_e$	V AC	110 – 500	110 – 500	110 – 500
Supply frequency		Hz	50/60	50/60	50/60
Control section power supply $U_c$		V AC	Internal through power terminal		
Rated operational current					
AC-53 (inductive load)	$I_e$	A	16	23	31
Assigned motor rating (standard connection)					
230 V		kW	4	5.5	7.5
400 V		kW	7.5	11	15
460 V		HP	10	15	20
500 V		kW	7.5	11	18.5
Overload cycle to IEC/EN 60947-4-2					
AC-53b (with bypass)			16 A: AC-53b: 3 – 5; 360	23 A: AC-53b: 3 – 5; 360	31 A: AC-53b: 3 – 5; 360
<b>Terminal capacities</b>					
Power cables					
Solid		mm <sup>2</sup>	1 × (1.5 – 6) 2 × (1.5 – 4)	1 × (1.5 – 6) 2 × (1.5 – 4)	1 × (2.5 – 50) 2 × (2.5 – 16)
Flexible with ferrule		mm <sup>2</sup>	1 × (1.5 – 6) 2 × (1.5 – 4)	1 × (1.5 – 6) 2 × (1.5 – 4)	1 × (2.5 – 35) 2 × (2.5 – 10)
Stranded		mm <sup>2</sup>	1 × (1.5 – 6) 2 × (1.5 – 4)	1 × (1.5 – 6) 2 × (1.5 – 4)	1 × (2.5 – 50) 2 × (2.5 – 16)
Solid or stranded		AWG	1 × (16 – 8) 2 × (16 – 10)	1 × (16 – 8) 2 × (16 – 10)	1 × (14 – 2) 2 × (14 – 8)
Tightening torque		Nm	1.7	1.7	3.5
Screwdriver (PZ: Pozidriv)		mm	PZ2 or 1 × 6 mm	PZ2 or 1 × 6 mm	PZ2 or 1 × 6 mm
Control cables					
Solid		mm <sup>2</sup>	1 × (0.75 – 2.5) 2 × (0.75 – 1.5)	1 × (0.75 – 2.5) 2 × (0.75 – 1.5)	1 × (0.75 – 2.5) 2 × (0.75 – 1.5)
Flexible with ferrule		mm <sup>2</sup>	1 × (0.75 – 2.5) 2 × (0.75 – 1.5)	1 × (0.75 – 2.5) 2 × (0.75 – 1.5)	1 × (0.75 – 2.5) 2 × (0.75 – 1.5)
Stranded		mm <sup>2</sup>	1 × (0.75 – 2.5) 2 × (0.75 – 1.5)	1 × (0.75 – 2.5) 2 × (0.75 – 1.5)	1 × (0.75 – 2.5) 2 × (0.75 – 1.5)
Solid or stranded		AWG	1 × (18 – 12) 2 × (18 – 16)	1 × (18 – 12) 2 × (18 – 16)	1 × (18 – 12) 2 × (18 – 16)
Tightening torque		Nm	0.8	0.8	0.8
Screwdriver		mm	0.5 × 3.5	0.5 × 3.5	0.5 × 3.5

### Notes

Rated impulse withstand voltage

- 1.2 μs/50 μs (pulse rise/fall time to IEC/EN 60947-2 or -3)
- Applies for control circuit/power section/enclosure



DS4 semiconductor contactors and soft starters

Moeller HPL0211-2004/32005

			DS4-340-7K5-MX(R)	DS4-340-11K-MX(R)	DS4-340-15K-MX(R)
<b>Power section</b>					
Rated impulse withstand voltage	$U_{imp}$	kV	6	6	6
Rated insulation voltage	$U_i$	V AC	500	500	500
Short-circuit rating					
Type "1" coordination					
At AC-53a:3-5:10-99 and AC-53b:3-5:360			PKM0-16 (+ CL-PKZ0) + Z00-16 (+ EZ00)	PKM0-25 (+ CL-PKZ0) + Z00-24 (+ EZ00)	PKZ2+M-32-PKZ2 (+ CL-PKZ2) + Z1-40 (+ EZ1)
Short-circuit rating type "2" coordination (in addition to the fuses for type "1" coordination)			3 × 50.140.06-63	3 × 50.140.06-80	3 × 20.282.20-125
Fuse holders			3 × 50.060.04	3 × 50.060.04	3 × 21.189.01
<b>Control circuit</b>					
Current consumption					
Minimum control voltage		V AC / DC	110 / 24	110 / 24	110 / 24
Digital inputs					
24 V DC		mA	14	14	14
230 V AC		mA	14	14	14
Control section power supply $U_c$		V AC	Internal through power terminal		
Control voltage					
DC operated		V DC	+24 ±15%	+24 ±15%	+24 ±15%
AC-operated		V AC	110 – 240 ±15%	110 – 240 ±15%	110 – 240 ±15%
Pick-up voltage					
DC operated		V DC	15 – 27	15 – 27	15 – 27
AC-operated		V AC	79 – 264	79 – 264	79 – 264
Drop-out voltage					
DC operated		V DC	0 – 3	0 – 3	0 – 3
AC-operated		V AC	0 – 22	0 – 22	0 – 22
Pick-up time					
DC operated		ms	95	95	95
AC-operated		ms	115	115	115
Drop-out time					
DC operated		ms	165	165	165
AC-operated		ms	165	165	165
Relay outputs					
Quantity			1	1	1
Voltage range		V AC	250	250	250
Current range, AC-1		A	3	3	3
<b>Soft start function</b>					
Ramp times					
Acceleration time		s	0.5 – 10	0.5 – 10	0.5 – 10
Delay time		s	0 – 10	0 – 10	0 – 10
Start pedestal		%	30 – 100	30 – 100	30 – 100

Notes

- Rated impulse withstand voltage
- 1.2 μs/50 μs (pulse rise/fall time to IEC/EN 60947-2 or -3)
  - Applies for control circuit/power section/enclosure





Moeller HPL0211-2004/2005

			DM4-340-7K5	DM4-340-11K	DM4-340-15K	DM4-340-22K
<b>General</b>						
Standards			IEC/EN 60947-4-2			
Approvals			UL, cUL	UL, cUL	UL, cUL	UL, cUL
Climatic proofing			Damp heat, constant according to IEC 60068-2-78; damp heat, cyclical, according to IEC 60068-2-30			
Ambient temperature	°C		0 – 40, to 60 °C with a current reduction of 2 % per °C			
Ambient temperature for storage	°C		-25/55	-25/55	-25/55	-25/55
Altitude	m		0 – 1000, to 2000 m with a current reduction of 1 % per 100 m			
Mounting position			Vertical			
Degree of protection			IP 20	IP 20	IP 20	IP 20
Contact protection			Finger- and back-of-hand proof			
Pollution degree			2	2	2	2
Heat dissipation at rated operational current $I_e$	W		50	63	91	120
Dimensions (w × h × d)	mm		222 × 290 × 195	222 × 290 × 195	222 × 290 × 195	222 × 290 × 195
Weight	kg		6.7	6.7	6.7	6.7
<b>Main contacts</b>						
Rated operational voltage	$U_e$	V AC	230 – 460	230 – 460	230 – 460	230 – 460
Rated insulation voltage	$U_i$	V AC	460	460	460	460
Supply frequency		Hz	50/60	50/60	50/60	50/60
Control section power supply $U_c$		V AC	110/230	110/230	110/230	110/230
<b>Rated operational current</b>						
AC-53a 400 V	$I_e$	A	16	23	30	44
<b>Assigned motor rating (standard connection)</b>						
230 V		kW	4	5.5	7.5	11
400 V		kW	7.5	11	15	22
460 V		HP	10	15	20	30
<b>Phase current</b>						
Delta connection		A	27	39	51	76
<b>Assigned motor rating (delta connection)</b>						
230 V		kW	7.5	11	15	22
400 V		kW	11	15	22	37
460 V		HP	20	25	30	50
<b>Overload cycle to IEC/EN 60947-4-2</b>						
AC-53a (without bypass)			16 A : AC-53a : 3 – 35 : 99–10	23 A : AC-53a : 3–35 : 99–10	30 A : AC-53a : 3–35 : 99–10	44 A : AC-53a : 3–35 : 99–10
AC-53b (with bypass)			16 A : AC-53b : 3 – 35 : 120	23 A : AC-53b : 3–35 : 120	30 A : AC-53b : 3–35 : 120	44 A : AC-53b : 3–35 : 120
<b>Short-circuit rating</b>						
Type "1" coordination			PKZM0-16	PKZM0-25	PKZ2/ZM-32	NZM7-63N
Additional type "2"			20.282.20-40	20.282.20-80	20.282.20-80	20.282.20-125

Moeller HPL0211-2004/2005

			DM4-340-30K	DM4-340-37K	DM4-340-45K	DM4-340-55K	DM4-340-75K	DM4-340-90K
<b>General</b>								
Standards								
IEC/EN 60947-4-2								
Approvals								
UL, cUL								
Climatic proofing								
Damp heat, constant according to IEC 60068-2-78; damp heat, cyclical, according to IEC 60068-2-30								
Ambient temperature								
0 – 40, to 60 °C with a current reduction of 2 % per °C								
Ambient temperature for storage								
-25/55								
Altitude								
0 – 1000, to 2000 m with a current reduction of 1 % per 100 m								
Mounting position								
Vertical								
Degree of protection								
IP 20								
Contact protection								
Finger- and back-of-hand proof								
Pollution degree								
2								
Heat dissipation at rated operational current $I_e$								
152								
Dimensions (w × h × d)								
222 × 290 × 195								
Weight								
6.7								
<b>Main contacts</b>								
Rated operational voltage								
230 – 460								
Rated insulation voltage								
460								
Supply frequency								
50/60								
Control section power supply $U_c$								
110/230								
<b>Rated operational current</b>								
AC-53a 400 V								
59								
<b>Assigned motor rating (standard connection)</b>								
15								
30								
40								
<b>Phase current</b>								
102								
<b>Assigned motor rating (delta connection)</b>								
30								
55								
75								
<b>Overload cycle to IEC/EN 60947-4-2</b>								
59 A : AC-53a : 3–35 : 99–10								
72 A : AC-53a : 3–35 : 99–10								
85 A : AC-53a : 335 : 603								
105 A : AC-53a : 3–35 : 99–10								
146 A : AC-53a : 3–35 : 99–10								
174 A : AC-53a : 3–35 : 99–10								
59 A : AC-53b : 3–35 : 120								
72 A : AC-53b : 3–35 : 120								
85 A : AC-53b : 3–35 : 120								
105 A : AC-53b : 3–35 : 120								
146 A : AC-53b : 3–35 : 120								
174 A : AC-53b : 3–35 : 120								
<b>Short-circuit rating</b>								
NZM7-63N								
20.282.20-125								
NZM7-80N								
20.189.20-200								
NZM7-100N								
20.189.20-200								
NZM7-100N								
20.610.32-350								
NZM7-160N								
20.610.32-350								
NZM7-200N								
20.610.32-450								

DM4 soft starters

DM4 soft starters



Moeller HPL0211-2004/2005

		DM4-340-7K5	DM4-340-11K	DM4-340-15K	DM4-340-22K
<b>Terminal capacities</b>					
Power cables					
Connection		–	–	–	–
Solid	mm <sup>2</sup>	1 × (1.5 – 16) 2 × (1 – 4)	1 × (1.5 – 16) 2 × (1 – 4)	1 × (1.5 – 16) 2 × (1 – 4)	1 × (1.5 – 16) 2 × (1 – 4)
Flexible with ferrule	mm <sup>2</sup>	1 × (1 – 16) 2 × (1 – 4)	1 × (1 – 16) 2 × (1 – 4)	1 × (1 – 16) 2 × (1 – 4)	1 × (1 – 16) 2 × (1 – 4)
Flexible with cable lug	mm <sup>2</sup>	–	–	–	–
Stranded	mm <sup>2</sup>	1 × (2.5 – 25) 2 × (2.5 – 4)	1 × (2.5 – 25) 2 × (2.5 – 4)	1 × (2.5 – 25) 2 × (2.5 – 4)	1 × (2.5 – 25) 2 × (2.5 – 4)
Stranded with cable lug	mm <sup>2</sup>	–	–	–	–
Solid or stranded	AWG	12 – 4	12 – 4	12 – 4	12 – 4
Flat conductor	No. layers × width × thickness mm	–	–	–	–
Busbar	Width mm	–	–	–	–
Tightening torque	Nm	2	2	2	2
Screwdriver (PZ: Pozidriv)	mm	0.8 × 4	0.8 × 4	0.8 × 4	0.8 × 4
Control cables					
Solid	mm <sup>2</sup>	1 × (0.75 – 2.5)	1 × (0.75 – 2.5)	1 × (0.75 – 2.5)	1 × (0.75 – 2.5)
Flexible with ferrule	mm <sup>2</sup>	1 × (0.75 – 2.5)	1 × (0.75 – 2.5)	1 × (0.75 – 2.5)	1 × (0.75 – 2.5)
Stranded	mm <sup>2</sup>	1 × (0.75 – 2.5)	1 × (0.75 – 2.5)	1 × (0.75 – 2.5)	1 × (0.75 – 2.5)
Solid or stranded	AWG	22 – 12	22 – 12	22 – 12	22 – 12
Tightening torque	Nm	0.5	0.5	0.5	0.5
Screwdriver	mm	0.6 × 3.5	0.6 × 3.5	0.6 × 3.5	0.6 × 3.5
<b>Control circuit</b>					
Current consumption					
Digital inputs					
24 V DC	mA	0.45	0.45	0.45	0.45
230 V AC	mA	4.5	4.5	4.5	4.5
Analog inputs					
10 V	mA	1	1	1	1
Pick-up voltage					
DC operated	V DC	24 – 230	24 – 230	24 – 230	24 – 230
AC-operated	V AC	24 – 230	24 – 230	24 – 230	24 – 230
Drop-out voltage					
DC operated	V DC	0 – 3	0 – 3	0 – 3	0 – 3
AC-operated	V AC	0 – 3	0 – 3	0 – 3	0 – 3
Programmable relay outputs					
Quantity		4	4	4	4
Max. voltage	V AC	250	250	250	250
Max. current AC-11	A	3	3	3	3
Programmable analog outputs					
Quantity		2	2	2	2
Voltage range	V DC	0 – 10	0 – 10	0 – 10	0 – 10
Current carrying capacity	mA	10	10	10	10
Programmable analog inputs					
Ref 1	V DC	0 – 10	0 – 10	0 – 10	0 – 10
Ref 2	mA	4 – 20	4 – 20	4 – 20	4 – 20
<b>Soft start function</b>					
Ramp times					
Acceleration time	s	1 – 255	1 – 255	1 – 255	1 – 255
Delay time	s	0 – 255	0 – 255	0 – 255	0 – 255
Start pedestal	%	10 – 60	10 – 60	10 – 60	10 – 60
Voltage drop on stop	%	0 – 100	0 – 100	0 – 100	0 – 100
Kick-start					
Voltage	%	60 – 90	60 – 90	60 – 90	60 – 90
Duration					
50 Hz	ms	100 – 400	100 – 400	100 – 400	100 – 400
60 Hz	ms	166 – 664	166 – 664	166 – 664	166 – 664
Current limitation		0.5 – 8 × I <sub>e</sub>	0.5 – 8 × I <sub>e</sub>	0.5 – 8 × I <sub>e</sub>	0.5 – 8 × I <sub>e</sub>

Moeller HPL0211-2004/2005

DM4-340-30K	DM4-340-37K	DM4-340-45K	DM4-340-55K	DM4-340-75K	DM4-340-90K
<b>Terminal capacities</b>					
Power cables					
Connection		–	–	M8 bolt for cable lug	M8 bolt for cable lug
Solid	mm <sup>2</sup>	1 × (4 – 35) 2 × (4 – 10)	1 × (4 – 35) 2 × (4 – 10)	–	–
Flexible with ferrule	mm <sup>2</sup>	1 × (6 – 35) 2 × (6 – 10)	1 × (6 – 35) 2 × (6 – 10)	–	–
Flexible with cable lug	mm <sup>2</sup>	–	–	35 – 95	35 – 95
Stranded	mm <sup>2</sup>	1 × (10 – 50) 2 × 10	1 × (10 – 50) 2 × 10	–	–
Stranded with cable lug	mm <sup>2</sup>	–	–	50 – 120	50 – 120
Solid or stranded	AWG	10 – 1	10 – 1	1 – 0 250 MCM	1 – 0 250 MCM
Flat conductor	No. layers × width × thickness mm	–	–	6 × 16 × 0.8	6 × 16 × 0.8
Busbar	Width mm	–	–	–	2 × (20 × 6)
Tightening torque	Nm	3	3	12	12
Screwdriver (PZ: Pozidriv)	mm	1.2 × 6.5	1.2 × 6.5	0.6 × 3.5	0.6 × 3.5
Control cables					
Solid	mm <sup>2</sup>	1 × (0.75 – 2.5)	1 × (0.75 – 2.5)	1 × (0.75 – 2.5)	1 × (0.75 – 2.5)
Flexible with ferrule	mm <sup>2</sup>	1 × (0.75 – 2.5)	1 × (0.75 – 2.5)	1 × (0.75 – 2.5)	1 × (0.75 – 2.5)
Stranded	mm <sup>2</sup>	1 × (0.75 – 2.5)	1 × (0.75 – 2.5)	1 × (0.75 – 2.5)	1 × (0.75 – 2.5)
Solid or stranded	AWG	22 – 12	22 – 12	22 – 12	22 – 12
Tightening torque	Nm	0.5	0.5	0.5	0.5
Screwdriver	mm	0.6 × 3.5	0.6 × 3.5	0.6 × 3.5	0.6 × 3.5
<b>Control circuit</b>					
Current consumption					
Digital inputs					
24 V DC	mA	0.45	0.45	0.45	0.45
230 V AC	mA	4.5	4.5	4.5	4.5
Analog inputs					
10 V	mA	1	1	1	1
Pick-up voltage					
DC operated	V DC	24 – 230	24 – 230	24 – 230	24 – 230
AC-operated	V AC	24 – 230	24 – 230	24 – 230	24 – 230
Drop-out voltage					
DC operated	V DC	0 – 3	0 – 3	0 – 3	0 – 3
AC-operated	V AC	0 – 3	0 – 3	0 – 3	0 – 3
Programmable relay outputs					
Quantity		4	4	4	4
Max. voltage	V AC	250	250	250	250
Max. current AC-11	A	3	3	3	3
Programmable analog outputs					
Quantity		2	2	2	2
Voltage range	V DC	0 – 10	0 – 10	0 – 10	0 – 10
Current carrying capacity	mA	10	10	10	10
Programmable analog inputs					
Ref 1	V DC	0 – 10	0 – 10	0 – 10	0 – 10
Ref 2	mA	4 – 20	4 – 20	4 – 20	4 – 20
<b>Soft start function</b>					
Ramp times					
Acceleration time	s	1 – 255	1 – 255	1 – 255	1 – 255
Delay time	s	0 – 255	0 – 255	0 – 255	0 – 255
Start pedestal	%	10 – 60	10 – 60	10 – 60	10 – 60
Voltage drop on stop	%	0 – 100	0 – 100	0 – 100	0 – 100
Kick-start					
Voltage	%	60 – 90	60 – 90	60 – 90	60 – 90
Duration					
50 Hz	ms	100 – 400	100 – 400	100 – 400	100 – 400
60 Hz	ms	166 – 664	166 – 664	166 – 664	166 – 664
Current limitation		0.5 – 8 × I <sub>e</sub>	0.5 – 8 × I <sub>e</sub>	0.5 – 8 × I <sub>e</sub>	0.5 – 8 × I <sub>e</sub>



Moeller HPL0211-2004/2005

		DM4-340-110K	DM4-340-132K	DM4-340-160K	
<b>General</b>					
Standards		IEC/EN 60947-4-2			
Approvals		UL, cUL	UL, cUL	UL, cUL	
Climatic proofing		Damp heat, constant according to IEC 60068-2-78; damp heat, cyclical, according to IEC 60068-2-30			
Ambient temperature	°C	0 – 40, to 60 °C with a current reduction of 2 % per °C			
Ambient temperature for storage	°C	-25/55	-25/55	-25/55	
Altitude	m	0 – 1000, to 2000 m with a current reduction of 1 % per 100 m			
Mounting position		Vertical	Vertical	Vertical	
Degree of protection		IP 20	IP 20	IP 20	
Contact protection		Finger- and back-of-hand proof			
Pollution degree		2	2	2	
Heat dissipation at rated operational current $I_e$	W	545	662	795	
Dimensions (w × h × d)	mm	338 × 520 × 248	338 × 520 × 248	338 × 520 × 248	
Weight	kg	15.7	22	22	
<b>Main contacts</b>					
Rated operational voltage	$U_e$	V AC	230 – 460	230 – 460	230 – 460
Rated insulation voltage	$U_i$	V AC	460	460	460
Supply frequency		Hz	50/60	50/60	50/60
Control section power supply $U_c$		V AC	110/230	110/230	110/230
Rated operational current					
AC-53a 400 V	$I_e$	A	202	242	300
Assigned motor rating (standard connection)					
230 V		kW	55	75	90
400 V		kW	110	132	160
460 V		HP	150	200	250
Phase current					
Delta connection		A	349	419	519
Assigned motor rating (delta connection)					
230 V		kW	110	132	160
400 V		kW	160	200	250
460 V		HP	250	350	400
Overload cycle to IEC/EN 60947-4-2					
AC-53a (without bypass)			202 A : AC-53a : 3–35 : 60–10	242 A : AC-53a : 3–35 : 60–10	300 A : AC-53a : 3–35 : 60–3
AC-53b (with bypass)			202 A : AC-53b : 3–35 : 360	242 A : AC-53b : 3–35 : 360	300 A : AC-53b : 3–35 : 360
Short-circuit rating					
Type "1" coordination			NZM7-200N	NZM7-250N	NZM10-400N/ZM-400
Additional type "2" coordination			20.610.32-450	20.610.32-500	20.610.32-500

Moeller HPL0211-2004/2005

DM4-340-200K	DM4-340-250K	DM4-340-315K	DM4-340-400K	DM4-340-500K
IEC/EN 60947-4-2				
UL, cUL	UL, cUL	UL, cUL	UL, cUL	UL, cUL
Damp heat, constant according to IEC 60068-2-78; damp heat, cyclical, according to IEC 60068-2-30				
0 – 40, to 60 °C with a current reduction of 2 % per °C				
-25/55	-25/55	-25/55	-25/55	-25/55
0 – 1000, to 2000 m with a current reduction of 1 % per 100 m				
Vertical	Vertical	Vertical	Vertical	Vertical
IP 20	IP 20	IP 20	IP 20	IP 20
Finger- and back-of-hand proof				
2	2	2	2	2
925	1371	1705	2106	2775
338 × 520 × 248	640 × 610 × 375	640 × 610 × 375	640 × 610 × 375	640 × 610 × 375
22	56	65	72	72
230 – 460				
230 – 460	230 – 460	230 – 460	230 – 460	230 – 460
460	460	460	460	460
50/60	50/60	50/60	50/60	50/60
110/230	110/230	110/230	110/230	110/230
370				
500	600	750	900	
110				
132	160	200	250	
200				
250	315	400	500	
300				
400	500	600	750	
640				
866	1039	1299	1558	
200				
250	315	400	500	
315				
400	560	750	900	
500				
600	850	1100	1300	
370 A : AC-53a : 3–35 : 60–3				
500 A : AC-53a : 3–35 : 60–3	600 A : AC-53a : 3–35 : 60–3	750 A : AC-53a : 3–35 : 60–3	900 A : AC-53a : 3–35 : 60–3	
370 A : AC-53b : 3–35 : 360				
500 A : AC-53b : 335 : 360	600 A : AC-53b : 3–35 : 360	750 A : AC-53b : 3–35 : 360	900 A : AC-53b : 3–35 : 360	
NZM10-400N/ZM-400				
20.610.32-630	NZM10-630N/ZM-630	NZM10-630N/ZM-630	NZM14-800S	NZM14-1000S
	20.610.32-900	20.610.32-900	20.610.32-1250	20.610.32-1250

DM4 soft starters

DM4 soft starters



Moeller HPL0211-2004/2005

			DM4-340-110K	DM4-340-132K	DM4-340-160K
<b>Terminal capacities</b>					
Power cables					
Connection			M8 bolt for cable lug	M8 bolt for cable lug	M8 bolt for cable lug
Flexible with cable lug		mm <sup>2</sup>	2 × (35 – 95)	2 × (35 – 95)	2 × (35 – 95)
Stranded with cable lug		mm <sup>2</sup>	2 × (50 – 120)	2 × (50 – 120)	2 × (50 – 120)
Solid or stranded		AWG	2 × 1/0 2 × 250 MCM	2 × 1/0 2 × 250 MCM	2 × 1/0 2 × 250 MCM
Flat conductor	No. layers × width × thickness	mm	2 × (6 × 16 × 0.8)	2 × (6 × 16 × 0.8)	2 × (6 × 16 × 0.8)
Busbar	Width	mm	2 × (20 × 6)	2 × (20 × 6)	2 × (20 × 6)
Tightening torque		Nm	12	12	12
Screwdriver (PZ: Pozidriv)		mm	0.6 × 3.5	0.6 × 3.5	0.6 × 3.5
Control cables					
Solid		mm <sup>2</sup>	1 × (0.75 – 2.5)	1 × (0.75 – 2.5)	1 × (0.75 – 2.5)
Flexible with ferrule		mm <sup>2</sup>	1 × (0.75 – 2.5)	1 × (0.75 – 2.5)	1 × (0.75 – 2.5)
Stranded		mm <sup>2</sup>	1 × (0.75 – 2.5)	1 × (0.75 – 2.5)	1 × (0.75 – 2.5)
Solid or stranded		AWG	22 – 12	22 – 12	22 – 12
Tightening torque		Nm	0.5	0.5	0.5
Screwdriver		mm	0.6 × 3.5	0.6 × 3.5	0.6 × 3.5
<b>Control circuit</b>					
Current consumption					
Digital inputs					
	24 V DC	mA	0.45	0.45	0.45
	230 V AC	mA	4.5	4.5	4.5
Analog inputs					
	10 V	mA	1	1	1
Pick-up voltage					
	DC operated	V DC	24 – 230	24 – 230	24 – 230
	AC-operated	V AC	24 – 230	24 – 230	24 – 230
Drop-out voltage					
	DC operated	V DC	0 – 3	0 – 3	0 – 3
	AC-operated	V AC	0 – 3	0 – 3	0 – 3
Programmable relay outputs					
	Quantity		4	4	4
	Max. voltage	V AC	250	250	250
	Max. current AC-11	A	3	3	3
Programmable analog outputs					
	Quantity		2	2	2
	Voltage range	V DC	0 – 10	0 – 10	0 – 10
	Current carrying capacity	mA	10	10	10
Programmable analog inputs					
	Ref 1	V DC	0 – 10	0 – 10	0 – 10
	Ref 2	mA	4 – 20	4 – 20	4 – 20
<b>Soft start function</b>					
Ramp times					
	Acceleration time	s	1 – 255	1 – 255	1 – 255
	Delay time	s	0 – 255	0 – 255	0 – 255
	Start pedestal	%	10 – 60	10 – 60	10 – 60
	Voltage drop on stop	%	0 – 100	0 – 100	0 – 100
Kick-start					
	Voltage	%	60 – 90	60 – 90	60 – 90
	Duration				
	50 Hz	ms	100 – 400	100 – 400	100 – 400
	60 Hz	ms	166 – 664	166 – 664	166 – 664
	Current limitation		0.5 – 8 × I <sub>e</sub>	0.5 – 8 × I <sub>e</sub>	0.5 – 8 × I <sub>e</sub>

Moeller HPL0211-2004/2005

			DM4-340-200K	DM4-340-250K	DM4-340-315K	DM4-340-400K	DM4-340-500K
<b>Terminal capacities</b>							
Power cables							
Connection			M8 bolt for cable lug	2 × M12 screws for cable lug	2 × M12 screws for cable lug	2 × M12 screws for busbar connection	2 × M12 screws for busbar connection
Flexible with cable lug		mm <sup>2</sup>	2 × (35 – 95)	2 × (50 – 240)	2 × (50 – 240)	–	–
Stranded with cable lug		mm <sup>2</sup>	2 × (50 – 120)	2 × (70 – 240)	2 × (70 – 240)	–	–
Solid or stranded		AWG	2 × 1/0 2 × 250 MCM	2 × 2/0 2 × 500 MCM	2 × 2/0 2 × 500 MCM	–	–
Flat conductor	No. layers × width × thickness	mm	2 × (6 × 16 × 0.8)	2 × (10 × 21 × 1)	2 × (10 × 21 × 1)	–	–
Busbar	Width	mm	2 × (20 × 6)	21 × 20	21 × 20	45 × 20 60 × 10 80 × 10	45 × 20 60 × 10 80 × 10
Tightening torque		Nm	12	24	24	24	24
Screwdriver (PZ: Pozidriv)		mm	0.6 × 3.5	0.6 × 3.5	0.6 × 3.5	0.6 × 3.5	0.6 × 3.5
Control cables							
Solid		mm <sup>2</sup>	1 × (0.75 – 2.5)	1 × (0.75 – 2.5)	1 × (0.75 – 2.5)	1 × (0.75 – 2.5)	1 × (0.75 – 2.5)
Flexible with ferrule		mm <sup>2</sup>	1 × (0.75 – 2.5)	1 × (0.75 – 2.5)	1 × (0.75 – 2.5)	1 × (0.75 – 2.5)	1 × (0.75 – 2.5)
Stranded		mm <sup>2</sup>	1 × (0.75 – 2.5)	1 × (0.75 – 2.5)	1 × (0.75 – 2.5)	1 × (0.75 – 2.5)	1 × (0.75 – 2.5)
Solid or stranded		AWG	22 – 12	22 – 12	22 – 12	22 – 12	22 – 12
Tightening torque		Nm	0.5	0.5	0.5	0.5	0.5
Screwdriver		mm	0.6 × 3.5	0.6 × 3.5	0.6 × 3.5	0.6 × 3.5	0.6 × 3.5
<b>Control circuit</b>							
Current consumption							
Digital inputs							
	24 V DC	mA	0.45	0.45	0.45	0.45	0.45
	230 V AC	mA	4.5	4.5	4.5	4.5	4.5
Analog inputs							
	10 V	mA	1	1	1	1	1
Pick-up voltage							
	DC operated	V DC	24 – 230	24 – 230	24 – 230	24 – 230	24 – 230
	AC-operated	V AC	24 – 230	24 – 230	24 – 230	24 – 230	24 – 230
Drop-out voltage							
	DC operated	V DC	0 – 3	0 – 3	0 – 3	0 – 3	0 – 3
	AC-operated	V AC	0 – 3	0 – 3	0 – 3	0 – 3	0 – 3
Programmable relay outputs							
	Quantity		4	4	4	4	4
	Max. voltage	V AC	250	250	250	250	250
	Max. current AC-11	A	3	3	3	3	3
Programmable analog outputs							
	Quantity		2	2	2	2	2
	Voltage range	V DC	0 – 10	0 – 10	0 – 10	0 – 10	0 – 10
	Current carrying capacity	mA	10	10	10	10	10
Programmable analog inputs							
	Ref 1	V DC	0 – 10	0 – 10	0 – 10	0 – 10	0 – 10
	Ref 2	mA	4 – 20	4 – 20	4 – 20	4 – 20	4 – 20
<b>Soft start function</b>							
Ramp times							
	Acceleration time	s	1 – 255	1 – 255	1 – 255	1 – 255	1 – 255
	Delay time	s	0 – 255	0 – 255	0 – 255	0 – 255	0 – 255
	Start pedestal	%	10 – 60	10 – 60	10 – 60	10 – 60	10 – 60
	Voltage drop on stop	%	0 – 100	0 – 100	0 – 100	0 – 100	0 – 100
Kick-start							
	Voltage	%	60 – 90	60 – 90	60 – 90	60 – 90	60 – 90
	Duration						
	50 Hz	ms	100 – 400	100 – 400	100 – 400	100 – 400	100 – 400
	60 Hz	ms	166 – 664	166 – 664	166 – 664	166 – 664	166 – 664
	Current limitation		0.5 – 8 × I <sub>e</sub>	0.5 – 8 × I <sub>e</sub>	0.5 – 8 × I <sub>e</sub>	0.5 – 8 × I <sub>e</sub>	0.5 – 8 × I <sub>e</sub>



# 17/46 Dimensions

## DS4 semiconductor contactors and soft starters

Moeller HPL0211-2004/2005

### Semiconductor contactors and soft starters

DS4-140-010H  
DS4-140-020H  
DS4-140-030H

DS4-340-2K2-M  
DS4-340-2K2-M-DC  
DS4-340-2K2-MR

DS4-340-7K5-MX  
DS4-340-7K5-MXR  
DS4-340-11K-MX  
DS4-340-11K-MXR

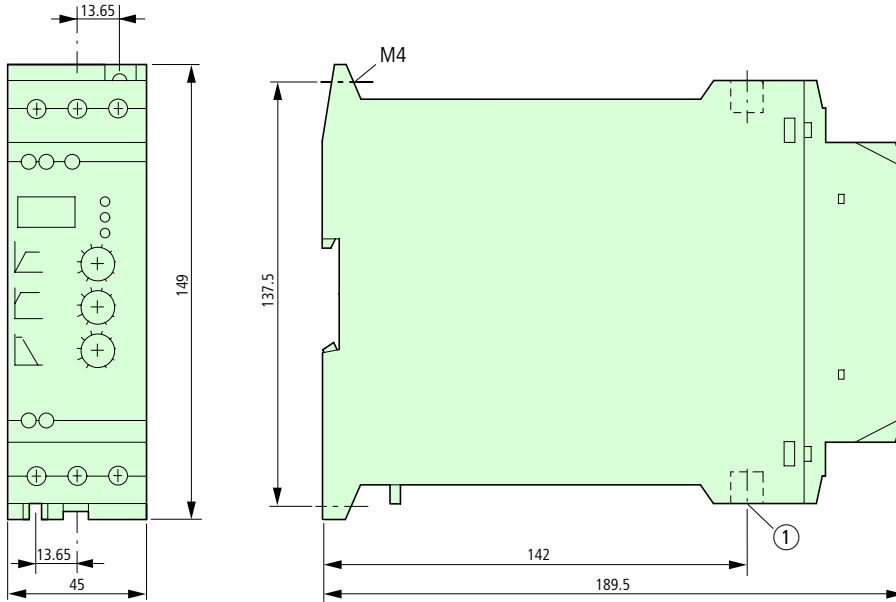

① 1L1, 3L2, 5L3  
2T1, 4T2, 6T3

DS4-140-050H

DS4-340-4K0-M  
DS4-340-5K5-M

DS4-340-4K0-MR  
DS4-340-5K5-MR

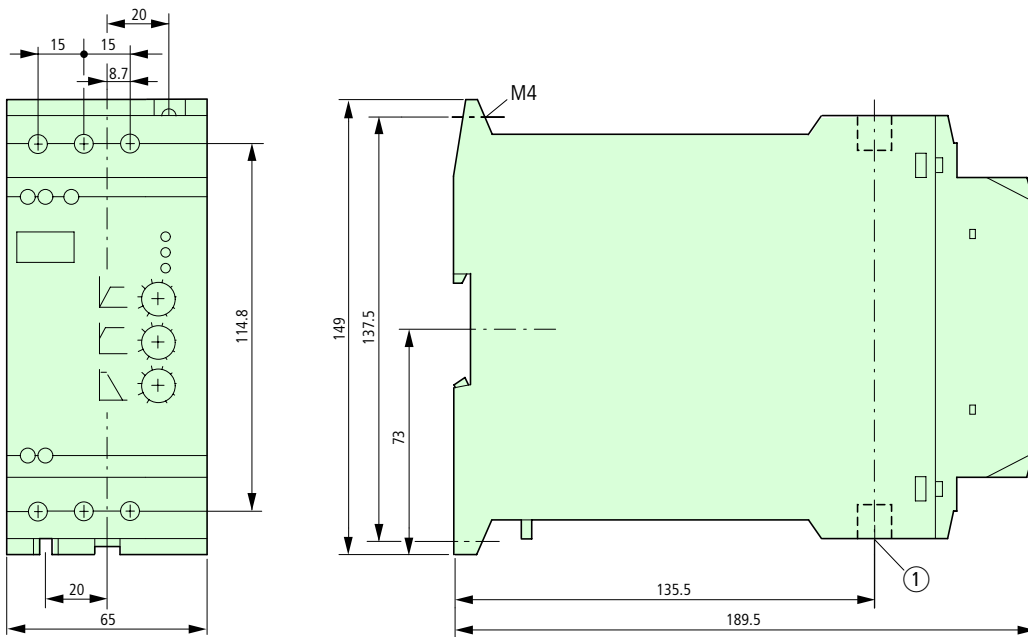

① 1L1, 3L2, 5L3  
2T1, 4T2, 6T3



Moeller HPL0211-2004/2005

Semiconductor contactors and soft starters

DS4-340-7K5-M  
 DS4-340-7K5-MR  
 DS4-340-11K-M  
 DS4-340-11K-MR

DS4-340-15K-MX  
 DS4-340-15K-MXR

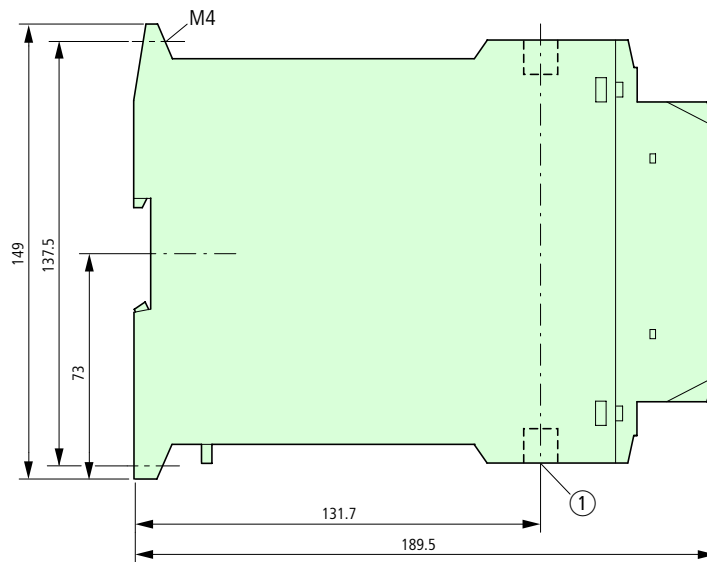
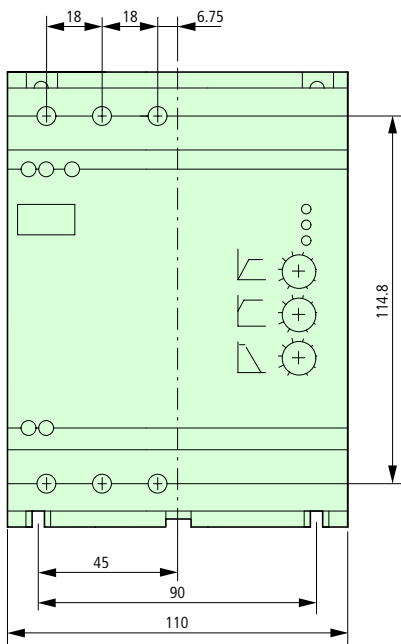

- ① 1L1, 3L2, 5L3  
 2T1, 4T2, 6T3



Fuses

51.063.04

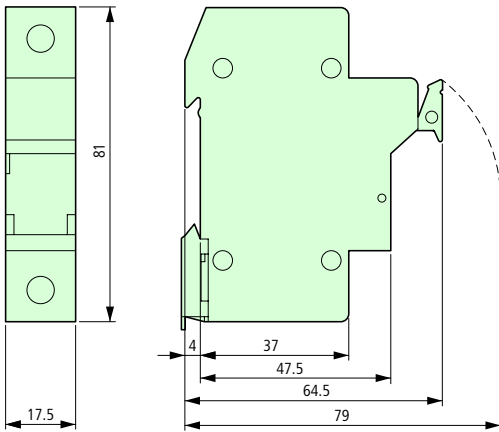

51.058.04

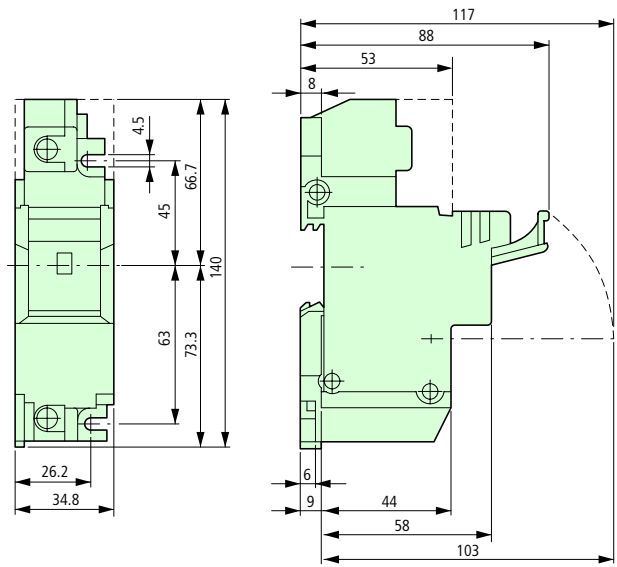

51.060.04

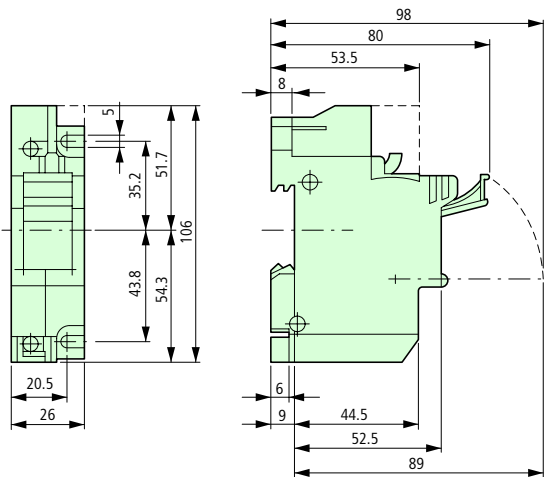

21.189.01

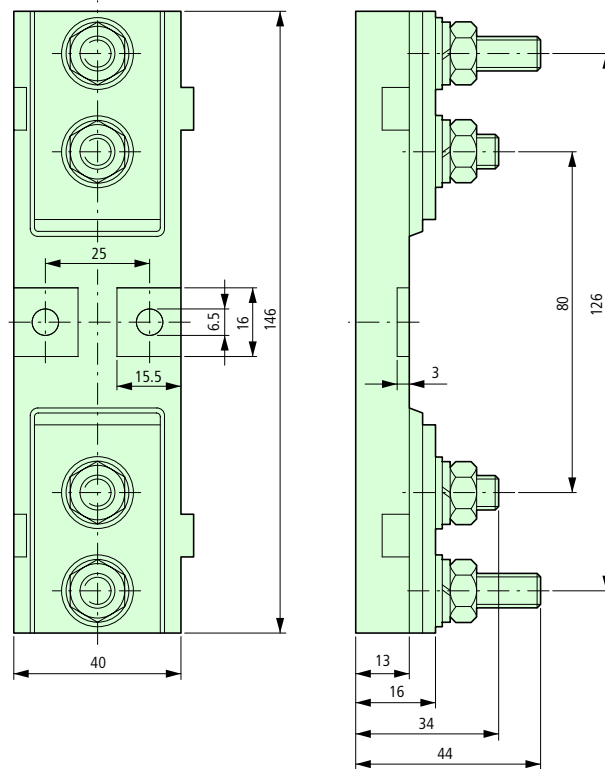

20.282.20-...

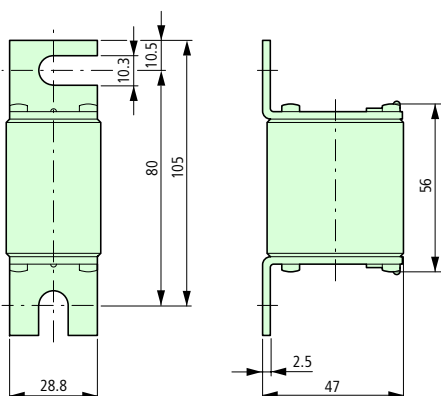

DS4 semiconductor contactors and soft starters

Moeller HPL0211-2004/2005

DM4-340...

- DM4-340-7K5
- DM4-340-11K
- DM4-340-15K
- DM4-340-22K
- DM4-340-30K
- DM4-340-37K

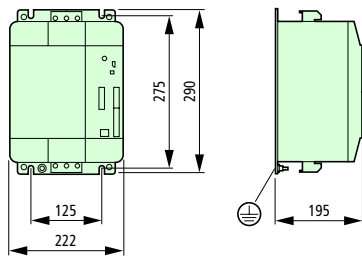

- DM4-340-45K
- DM4-340-55K
- DM4-340-75K

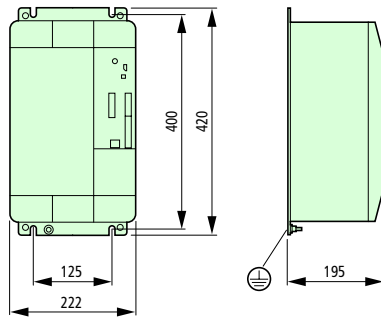

- DM4-340-90K
- DM4-340-110K
- DM4-340-132K
- DM4-340-160K
- DM4-340-200K

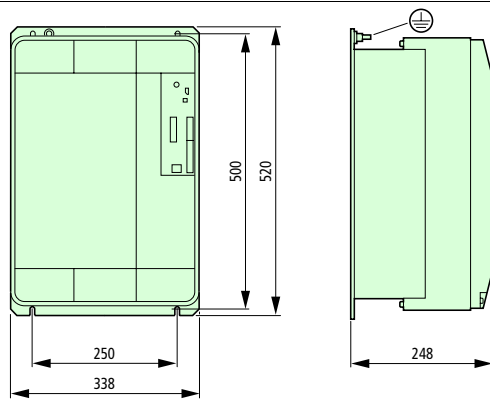

- DM4-340-250K
- DM4-340-315K
- DM4-340-400K
- DM4-340-500K

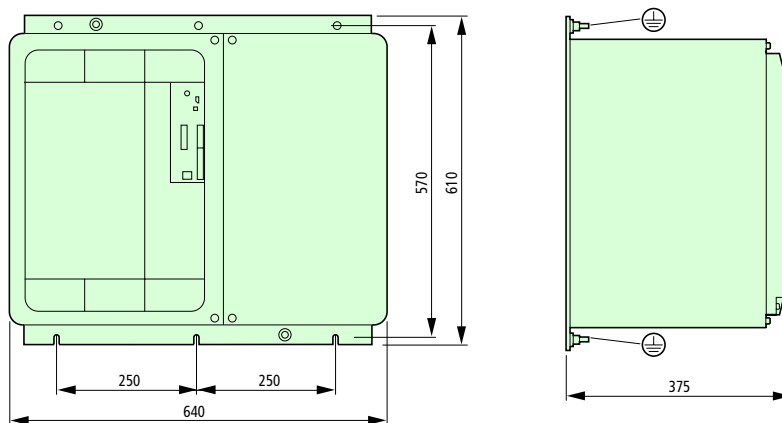

Keypad for DM4

DE4-KEY-2

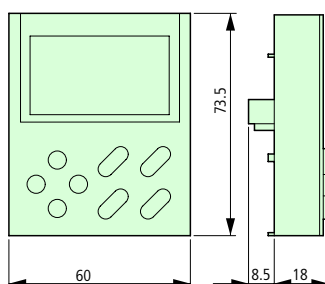



RS 232/RS 485 serial interface

DE4-COM-2X

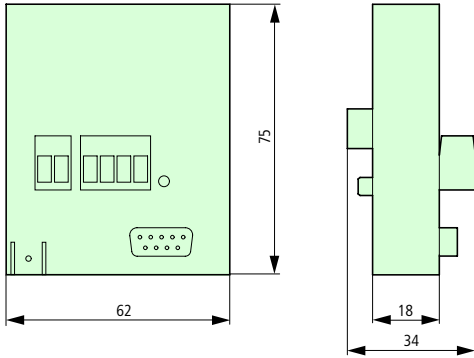

PROFIBUS DP fieldbus module

DE4-NET-DP2

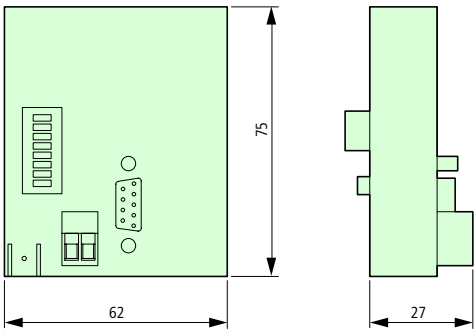

Suconet K fieldbus module

DE4-NET-K

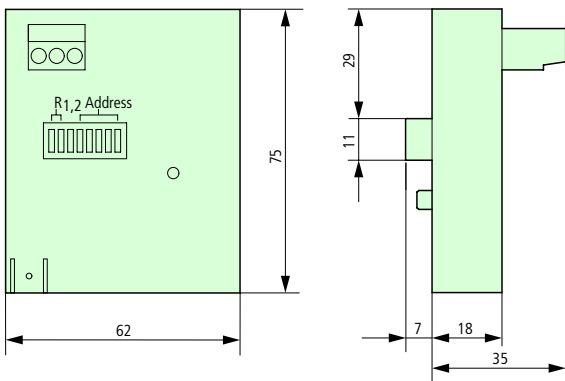

Moeller HPL0211-2004/2005

Fuse bases

21.313.02

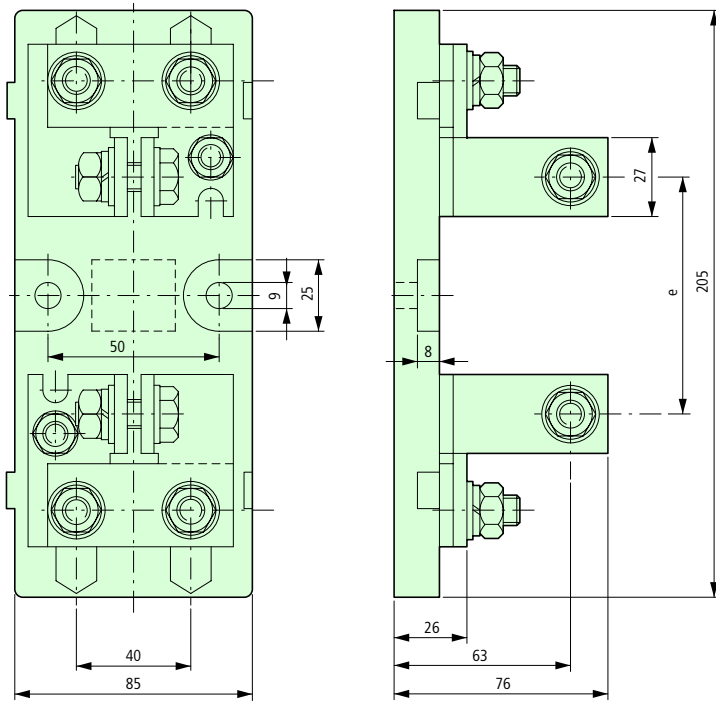

21.189.01

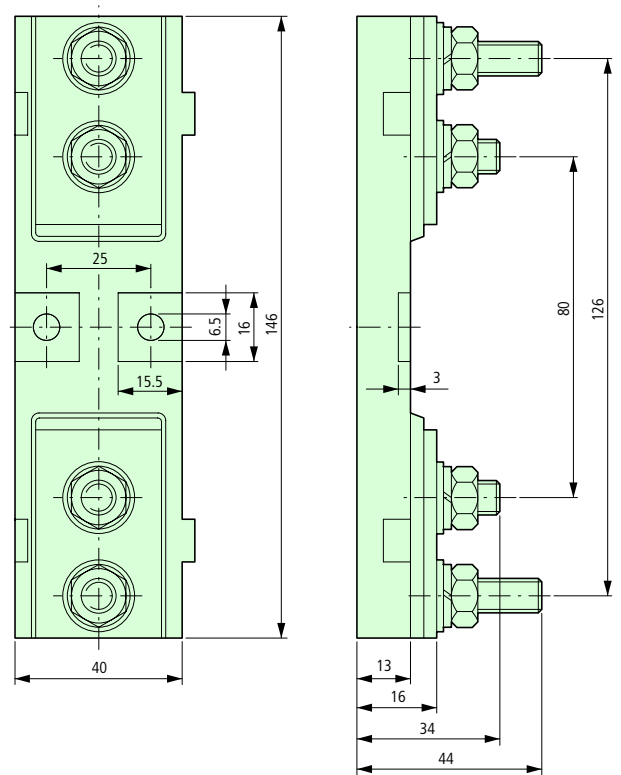

Fuses

20.282.20-...

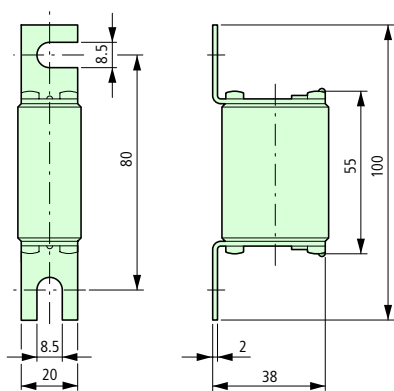

20.189.20-...

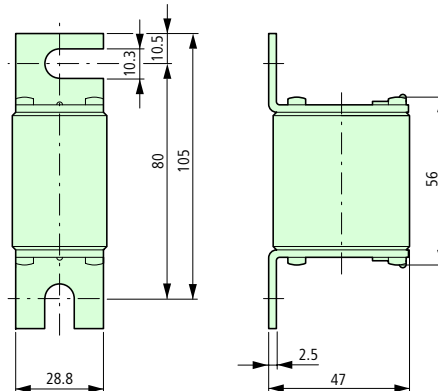

20.6x0.20

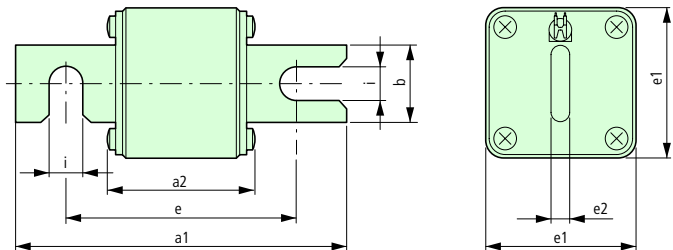

Type	a1	a2	b	e	e1	e2	i
20.610.32-350	109	47.5	26	76	51	6	11
20.610.32-450	109	47.5	26	76	51	6	11
20.610.32-500	109	47.5	26	76	51	6	11
20.610.32-630	109	47.5	26	76	51	6	11
20.630.32-900	109	49	35	76	73	6	11
20.630.32-1250	109	49	35	76	73	6	11

